

# **KELCO E30 Mk2 DIGITAL PRESSURE SWITCH**

## **INSTALLATION & PROGRAMMING MANUAL**

**Version 070218**

# IMPORTANT: READ THIS FIRST

**DO NOT EXPOSE THE E30 Mk2 TO VIBRATION. INSTALL ONLY IN PIPEWORK THAT DOES NOT VIBRATE.** *Vibration will damage the electronics within the E30 and will void your product warranty.*

This E30 Mk2 digital pressure switch has been fully tested and calibrated. It is set to use kPa in mode 1 and it has its start-up and run-on timers both set to 5 seconds. It is set to close relay 1 at 100kPa and open it at 200 kPa. All other functions are turned off. On start up, the E30 will run a pump connected to relay 1, using its start-up timer. If it finds pressure in the pipe system it will continue to run the pump. If pressure is lost, the pump will continue to run for 5 seconds, held on by the E30's run-on timer. If pressure fails to return, the pump will be shut down after the run-on period. Pressing and releasing the **(R)** button on the E30 will repeat this basic process.

## THE BUTTONS

The E30 Mk2 is controlled and configured using 4 onboard buttons.

- (R) Reset button.** Stops the pump(s) and restarts the E30 when released.
- (^) Up arrow button.** For increasing program settings.
- (v) Down arrow button.** For decreasing program settings.
- (P) Programming button.** For stepping through the menu and entering settings into memory.

## THE LIGHTS

The E30 Mk2 includes 3 multicolour lights to indicate activity.

**Pump:** This light is **GREEN** when a pump is running and **RED** when the pump is stopped.

**Timer:** This light may be **GREEN** or **RED** when a timer or special function is running.

**Remote:** This light is **BLUE** when remote input No. 1 is closed and off when the remote is open. The light is **RED** when remote input No. 2 is closed and off when the remote is open. This light is **PURPLE** when both remote inputs 1 & 2 are closed.

## **LCD SCREEN BACKLIGHT**

The LCD backlight can be turned on or off.

To turn the light off press and hold down the **(V)** button. Press and release the **(R)** button. Release the **(V)** button. Repeat to turn the light on. The light remembers the state it was last left in, if power is turned off. The light can be left permanently on or off as required.

## **TEMPERATURE**

The E30 monitors its internal temperature when running. Pressing the **(V)** button while the controller is operating normally displays the current internal temperature.

## **PRESS (and release) THE (P) BUTTON**

When the E30 is powered up, pressing the **(P)** button, holding it down for 1 second and releasing it takes you to the top of the menu. Pressing and releasing the **(P)** button loads whatever the screen is displaying into the E30's memory. The memory is non-volatile and settings are retained when power is off. You can exit the menu at any time by pressing and releasing the **(R)** button. Any settings you have made up to that point will be retained. There is no need to step all the way through the menu when making a change to a setting.

## **INSTALLING THE E30 Mk2**

*1) Do not install the E30 in a fully exposed outdoor location. The E30 is weatherproof, however, to ensure a long reliable life, we recommend it be protected from direct exposure to the sun and rain. A skull cap is provided with the E30 and we recommend it be used to protect the E30 when direct observation of the LCD screen is not required.*

*2) Do not expose the E30 to freezing. If the pipework in which the E30 is installed freezes, the pressure sensor in the E30 may fail. If the E30 is to be used in areas where low temperatures will be encountered, always lag the pipework for several metres either side of the E30. Also lag the base of the E30 to prevent the unit and any adjacent pipework from freezing.*

*3) Do not use this controller in hot water applications. The E30 is not designed to be used in water hotter than 60°C.*

***4) Never expose the E30 to static or dynamic pressures greater than 20 Bars, 290 psi.***

***5) Do not install the E30 in a section of pipe that is subject to vibration. Vibration will cause premature failure of the electronic components within the controller.***

***6) Never install the E30 in the suction pipe of the pump or in any location where it may be subject to partial vacuum conditions.***

## **LOCATION**

Install the E30 in a location that is sheltered from direct exposure to the weather. The E30 is weatherproof and is supplied with a protective cover. However, to ensure a long reliable life from the E30 we recommend it be protected from direct exposure to the weather wherever possible. Intense sun light will eventually cause degradation of the pressure switch's enclosure and in extreme cases may cause overheating of the electronics inside the E30. It is therefore advisable to protect the E30 from the weather whenever possible.

The E30 can be wall mounted using the wall mounting bracket kit supplied with each unit or it can be installed directly onto pipework. The location of the tapping point is important. The E30 responds to positive pressures only. It should never be installed in pipework that is subject to partial vacuum (negative pressures). Do not install the E30 in the suction pipework of a pump. The tapping point should be in a location that is away from valves, elbows and concentric reducers. The E30 can be installed in either horizontal or vertical pipework. Flow direction has no impact on the performance of the pressure switch. Install the E30's tapping point in a section of pipe that typifies the pipework in the general system. If water hammer is a potential issue in the system's pipework, wall mount the E30 and run a length of small diameter capillary tube between the tapping point and the E30. Coil the capillary tube so the tube acts as a snubber and absorbs the pressure shock from the water hammer.

The E30 will read the line pressure at its tapping point. Consideration should be given to the layout of the pipework and its effect on the reading accuracy. If the system is subject to dynamic pressure, that is, pressure generated as a function of fluid movement within the pipe system, then the location of the tapping point will effect the E30's ability to read the pressure in a sensible manner. If the pipe system is only subject to static pressure, that is, pressure that may fluctuate but is from essentially stationary liquid within the system, then the tapping point is unimportant as pressure within such a closed system will be uniform at all points.

## DYNAMIC PRESSURE

Consider the sections of pipe depicted in the sketch below. In sketch (A) the pressure as read by the E30 when water flows will be less than the pressure read by the pressure gauge. The difference between the two readings will be directly related to the flow velocity and the ratio of the two pipe diameters. The E30 will see the pressure as lower than that seen by the pressure gauge. This is due to the higher velocity through the small pipe and thus lower pressure than the pressure in the larger pipe where the velocity is lower. In sketch (B) both the pressure gauge and the the E30 will read the same pressure since the velocity is constant between the two tapping points. In sketch (C) the E30 will read the dynamic pressure as higher than the pressure as read by the pressure gauge. This is the reverse of the situation in sketch (A)

Note that in a static situation with no flow the pressure gauge and the E30 will read the same pressure in all three pipe configurations.

Careful consideration should therefore be given to the location of the tapping point. When water is flowing the tapping points location will effect the pressure reading and thus what the E30 actually displays.

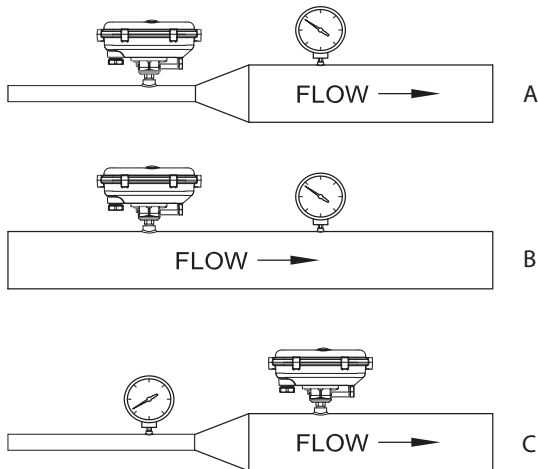

## INSTALLATION

The E30 consists of two separate parts, the process connection and the electrical housing. The two parts are locked together by an Allen screw located under the electrical housing. As supplied, the two parts are separate allowing the process connector to be screwed onto pipework using a suitable 1/4" BSP pipe nipple (not included). The provision of a separate process connector means the E30 can be easily installed in awkward locations particularly when the tapping point is located close to pipe bends or other obstructions. In effect, the process connection acts as a union and can be screwed onto a pipe nipple and installed in the pipework. The electrical housing can then be fitted onto the process connection and locked in place with the Allen screw.

To lock the two parts of the E30 together, with the electrical housing located on the spigot and in position, press down with the flat of your hand on the top face of the lid of the electrical enclosure. While pressing down, screw the 4mm Allen screw fully through the housing using the 3mm Allen Key (supplied). Tighten the screw and then release your hand from the top of the housing. Pressing down with your hand on the housing preloads the O-ring seal between the housing and the process connection. It enables the M4 Allen screw to easily screw fully through the side of the housing. Do not screw the Allen screw through the housing without first preloading the O-ring in the manner described above. To do so will result in the Allen screw cutting a thread through the housing and reducing the designed preload against the O-ring. This in turn will compromise the seal between the two parts of the pressure switch.

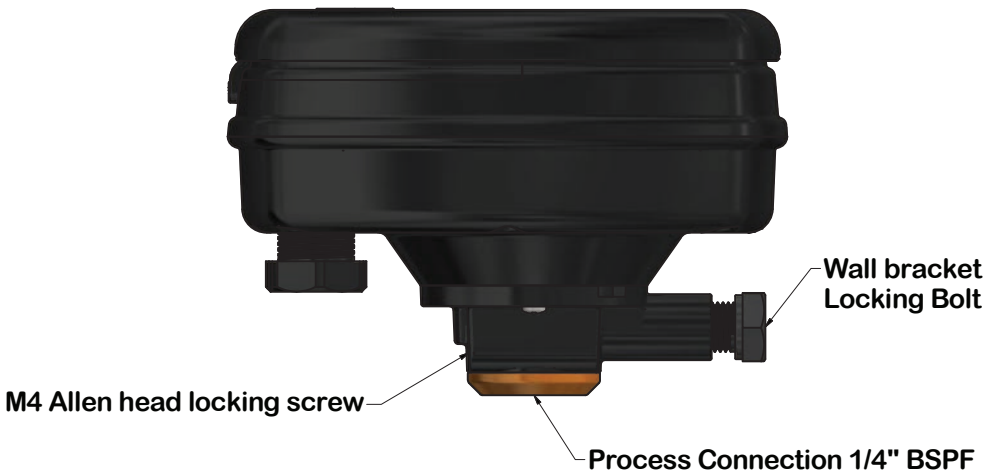

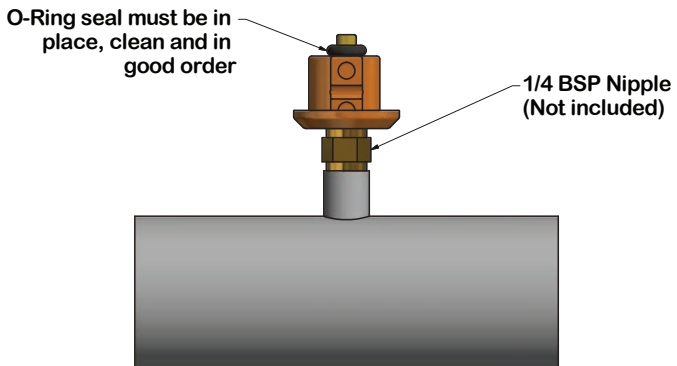
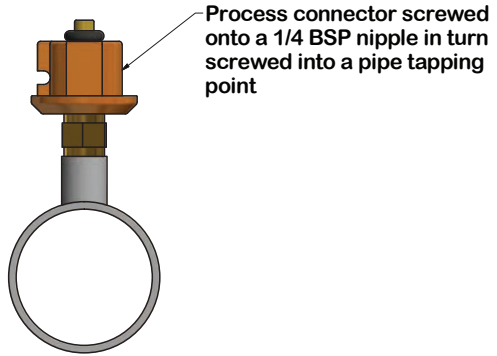
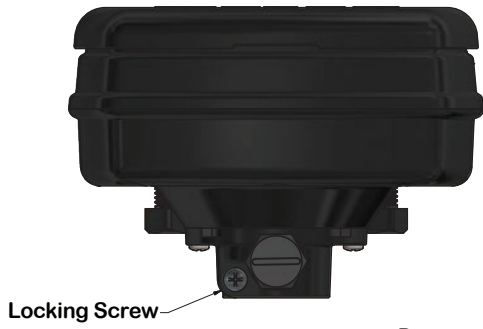

## E30 MOUNTED DIRECTLY ON A PIPE

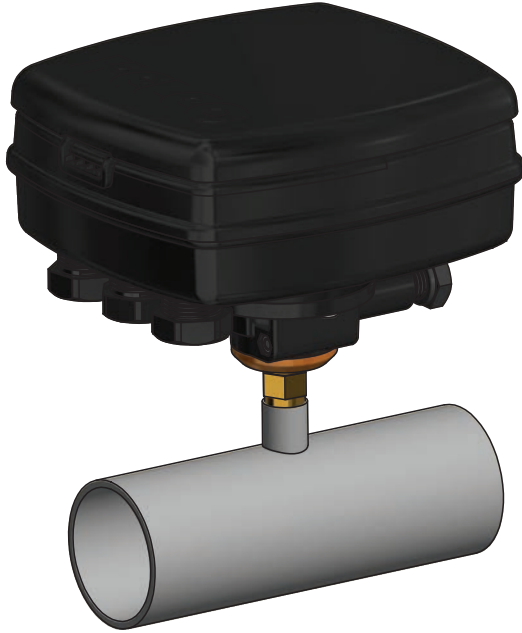

### ATTACHING THE ELECTRICAL HOUSING

Once the process connector has been installed, fit the electrical housing onto the spigot on top of the process connector. Take care that the sealing O-ring on the top stem of the assembly is in location and in good order. There is a flat keying face on the cylindrical body of the process assembly that keys the electrical housing onto the process assembly and aligns it correctly. To secure the electrical housing onto the process adaptor an Allen head cap screw is supplied.

With the electrical housing located on the spigot and in position, press down with the flat of your hand on the top face of the electrical enclosure. While pressing down, screw the 4mm Allen screw fully through the housing using the 3mm Allen Key (supplied). Tighten the screw and then release your hand from the top of the housing.



## DETACHING THE ELECTRICAL HOUSING

**WARNING:** *Always switch off the power and de-pressurise the pipe system before attempting to remove the electrical housing.*

To allow easy removal of the E30 from the pipework, the electrical housing can be detached from the process adaptor. Removing the electrical housing allows access to the process adaptor without the need to disconnect wiring. To remove the electrical assembly undo and completely remove the M4 Allen head locking screw. Once the locking screw is removed, lift the electrical housing straight off, do not twist it when doing this. Once the electrical housing has been removed, the process adaptor can be unscrewed from the pipework. Simply reverse this procedure to refit the electrical housing to the E30, taking care to ensure the O-ring on the top of the process adaptor is in place and is clean and in good condition.

## WALL MOUNTING THE E30

The E30 pressure switch is supplied with a wall mounting bracket that can be used to mount the pressure switch in locations away from the pressure tapping point. To bracket mount the E30, first install the bracket by drilling a hole pattern. Secure the bracket to the wall or mounting using suitable screws (not supplied). Fit a 1/4" BSP elbow (not supplied) to the E30's process port using Teflon tape. The elbow should point squarely toward the cable glands on the E30. Install a suitable tube adaptor into the elbow to facilitate connection to a length of capillary tube. Typically, the capillary tube to use for this will be 6 to 8mm diameter.

Wire up the electrical head of the E30 and fully tighten all cable glands. Lock the electrical head onto the wall bracket using the red bolt supplied with the E30. Note that there are two ears on the wall bracket that engage in two notches on the under side of the E30's electrical housing. Using a suitable tube adaptor terminate the capillary tube at the pipe system's tapping point. If water hammer or violent pressure surges are likely, coil the capillary tube between its two termination points so the added length of the capillary tube acts as a shock absorber.

## TYPICAL WALL MOUNTED E30 Mk2

The single locking bolt secures the E30 to the wall Bracket

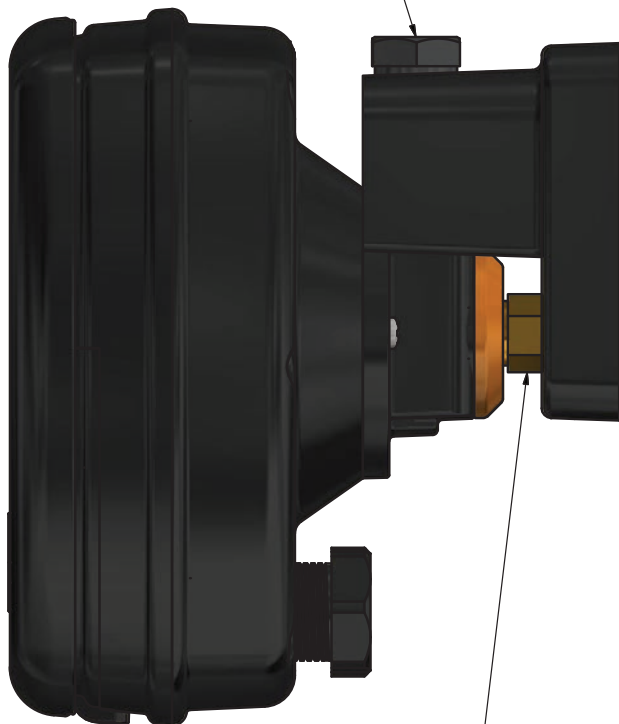

Screw a 1/4 BSP 90 Degree elbow (not supplied) into the process port on the E30. The inlet port on the elbow must be aligned downward to accept a capillary tube adaptor and to stand clear of the wall

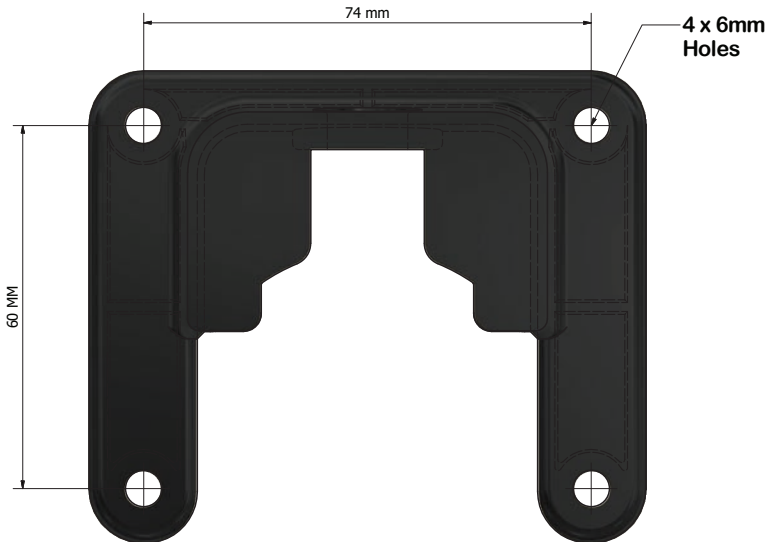
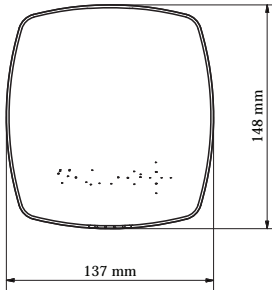
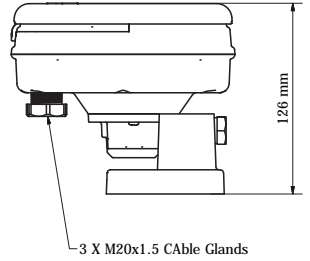
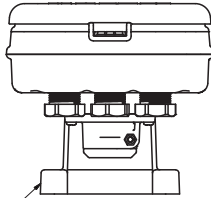
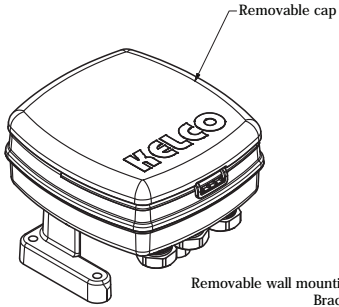
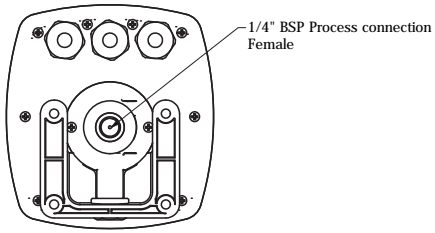

WALL BRACKET DRILL PATTERN

# ELECTRICAL INSTALLATION



## WARNING

All electrical work associated with the E30 must be carried out by qualified electrical personnel and all electrical work must conform to AS/NZ standards and to local wiring rules.

## INTRODUCTION

When used with its HD terminal link in place the E30 can directly control single-phase motors to 2.4kW via its Relay 1. No interposing contactor is required for such applications. The E30 can also be used to control 3 phase motors of any size via an appropriate interposing contactor.

**WARNING:** *The contactor control circuit must never exceed 240VAC. Never series connect the E30 relay contacts and contactor coil directly across 2 phases.*

The E30 requires a stable 220V to 240V AC supply when operated from the mains. It can also be operated from an 18 to 24V AC or DC supply by utilising the low voltage active terminal FELV and neutral terminal N (see the included wiring diagrams). When operated from a low voltage DC supply the terminals FELV and neutral N are not polarity sensitive. Pay attention to cable sizes and ensure cables are adequate for the specific pump motor load. This is particularly important where long cable runs are to be used in the installation. If the voltage drop associated with the starting of the pump motor is excessive the E30 may repeatedly reset and not operate properly.



## WARNING

**The HD terminal must be left unused or only ever linked to Relay 1 Normally Open. It must never be used for any other purpose and it must never be connected to any external device. Under no circumstances connect the HD terminal to the terminals of Relay 2. The HD terminal must be regarded as live at all times and at full mains potential.**

## THE HD (Heavy Duty) TERMINAL

The E30 contains a solid-state switch (HD Heavy Duty drive) that can be used to protect the contacts of Relay 1 by eliminating the destructive arcing caused by the starting and stopping of motors. The solid-state switch is accessible from the HD terminal on the terminal block. We recommend the HD drive be used whenever the E30 is used to directly control a single phase motor. The HD drive should not be used when the E30 is connected to a contactor, external timer, low wattage relay or to any other external device where voltage free contacts are required. It is strictly intended for the direct control of highly inductive AC motor loads. The HD terminal and the E30's built in relays must never be directly connected to a DC motor under any circumstances.

When the HD terminal is linked to the normally open terminal of Relay 1, the HD drive in effect parallels a 42 Amp solid state switch across the relay's normally open contacts. This increases the momentary current carrying capacity of the relay's contacts to well over 60 Amps. The solid-state HD drive is only activated for a brief period when the motor starts and stops. It effectively handles the high inrush current associated with the motor starting, and it provides a current path for the destructive back EMF associated with the motor stopping. **To use the HD drive, place a heavy link wire between the HD terminal and the Normally Open terminal of Relay one.**

## BROWNOUT OR BLACKOUT

If a blackout or brownout occurs the E30 will not retain any memory of where in its run or stop cycle it may have been, it will simply shut down the pump. When power resumes, the E30 will reboot, and under acceptable pressure conditions, restart the pump and run any timer settings from the beginning. A manual reboot can be done at any time by pressing and releasing the E30's reset button.

## CABLES

The E30 Mk2 has 3 X M20 cable glands. The cable glands can accept cable from 7 to 9mm diameter. See sketch for assembling the cable gland components. The controller is supplied with a set of steel crimp rings. The crimp rings are to provide strain relief for the controller's cables. To use the crimps, place one on the cable approximately 3 to 4mm below the end of the cable's outer sheathing. Crimp the two ears of the ring flat using bull nosed pliers. Pull the cable back through the cable gland until the crimp ring's ears are fully located into the slots in the cable gland housing.

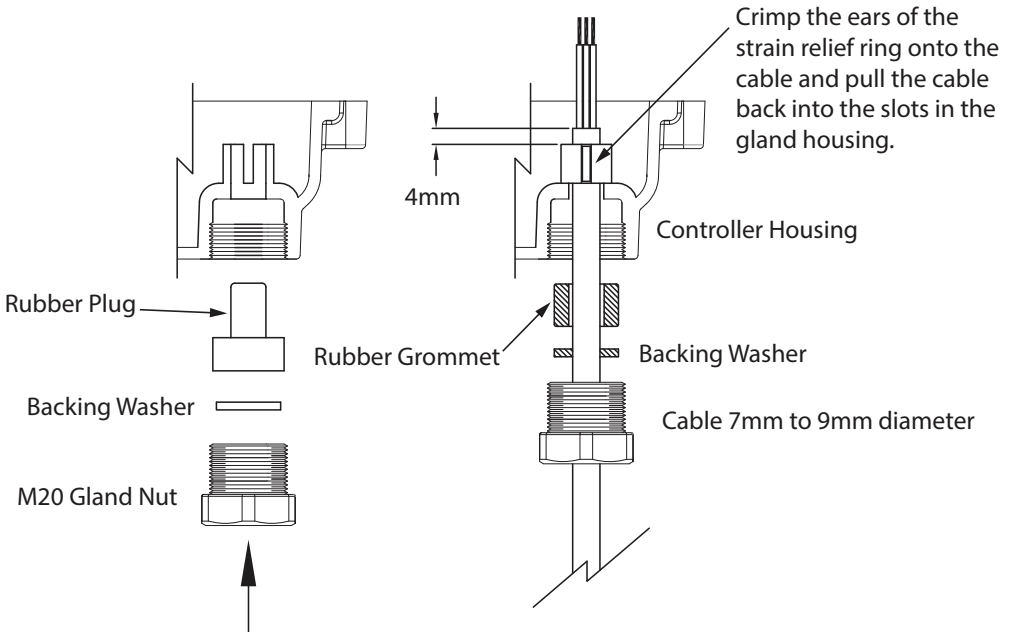

Plug unused cable glands using the rubber plugs (supplied). Fully tighten the gland nut to seal the unused cable port.

## SUPPLY VOLTAGE LIMITATIONS

VOLTAGE LIMITS ON TERMINALS A & N	
Maximum Supply Voltage	260VAC
Minimum Supply Voltage	110VAC

VOLTAGE LIMITS ON TERMINALS FELV & N	
Maximum Supply Voltage	25VAC 50/60Hz or 25VDC
Minimum Supply Voltage	18VAC 50Hz or 18VDC

## RELAYS

The E30 Mk2 houses 2 relays. Relay 1 has S.P.D.T contacts. Relay 2 has S.P.S.T normally open contacts. Relay 1 is normally regarded as the pump control relay and relay 2 is normally regarded as the alarm relay. When operating the E30 as a dual pump controller, relay 2 is used to control the second pump.

***With the HD terminal linked to the NO terminal of Relay 1, the E30 can directly control a single phase motor up to 2.4kW. Without the HD terminal link in place, relays 1 & 2 are limited to directly controlling a motor to 0.75kW. Both relays can control motors of any size via interposing contactors.***

CONTACT RATINGS FOR RELAYS 1 & 2	
16A at 250VAC	Resistive Load PF > 0.9
16A at 30VDC	Resistive Load PF > 0.9
50mA at 5VDC	Minimum Load

## POWERING THE E30

The power required to drive the E60 depends on the supply, AC or DC and on temperature. The table below gives the maximum power required from various supplies at 25°C. As temperature increases the power requirement will reduce. For example, at 30°C the power requirement will be approximately 3% less than the values given in the table. The measurements expressed in the table represent the maximum required power with both relays 1 and 2 closed and the LCD backlight and all indicator lights on.

POWER REQUIRED TO DRIVE THE STANDARD E30	
24VDC Supply to FELV & N	Maximum 68mA 1.63Watts
24VAC 50/60Hz Supply to FELV & N terminals	Maximum 108mA 2.34Watts
220VAC 50Hz Supply to A & N	Maximum 87mA 2.00Watts

POWER REQUIRED TO DRIVE THE 12VDC E30-12	
With Both Relays Closed	68mA Max at 12VDC 0.81W
With One Relay Closed	52mA Max at 12VDC 0.62W
Quiescent State (relays open)	25mA Max at 12VDC 0.30W

The E30 must always be powered from the same source as the supply to the external switch. The supply to the remote switch on the E30-12 (low voltage DC model) must be taken from the supply positive terminal. In all cases the external switch return wire must be connected to the Remote input terminal on the E30. The Supply to the external switch will range from 12 to 24 VDC or from 20 to 35V AC depending on the supply voltage.

## REMOTE INPUTS

**WARNING:** *The low voltage source available at the FELV terminal is non-isolated and must be regarded as operating at full mains potential whenever the F60 is powered from the mains. FELV means Functional Extra Low Voltage and refers to a non-isolated extra low voltage source.*



The E30 Mk2 has two remote inputs marked RMT1 and RMT2. Remote input 1 can be configured to operate in various ways in the program such as start and stop for connection to tank level switches or for connection to a remote flow switch in dual pump mode. Remote input 2 has a fixed function, it replicates the main reset button on the E30. A normally open remote reset switch can be used to reboot the E30 by connecting it to RMT2.

An external switch with voltage free contacts such as a tank level switch or a set of external relay contacts can be used to control the E30. The supply to the external switch must be taken from the FELV terminal on the E30 when the controller is powered from the mains or from a 24VAC source. The E30 must always be powered from the same source as the supply to external switch. The supply to the remote switch on the E30-12 (low voltage DC model) must be taken from the supply positive terminal. In all cases the external switch return wire must be connected to the correct remote input terminal on the E30. The supply to the external switch will range from 12 to 24 VDC or from 20 to 35V AC depending on the supply voltage.

***WARNING: Never connect an external power source of any kind to the E30's remote input terminals.***

The remote switch can be installed some distance from the E30. The maximum distance is limited by cable resistance and capacitance. The total cable resistance must not exceed 5K Ohms with the remote switch closed. The total capacitance of the cable must not exceed 25nF with the remote switch open. Wires to the remote switch should be run separately from power carrying cables. Do not run the remote switch wires in a conduit that also contains power cables. Capacitive coupling between the adjacent cables may cause false triggering of the E30's remote inputs. For cable runs longer than 150 metres we suggest using 2 separate wires to reduce capacitive coupling between the adjacent wires. When set up this way cable resistance becomes the limiting factor for distance. The table below sets out the resistance of typical copper wire of various diameters.

Note that the cable resistance refers to the total resistance out to the remote switch and back, as measured at the controller across the 2 remote

## EXAMPLE

A water tank is located 2000 metres from the E30. Two separate wires each 0.2mm<sup>2</sup> are run to the remote tank (total wire length is 4000 metres). The resistance as measured across the 2 wires back at the E30 (with the tank level switch closed) is 382 Ohms. This is well under the 5,000 Ohm limit. The remote input to the E30 will operate properly provided the wires are separated by sufficient distance that the capacitance between them is less than 25nF. Capacitance should be measured between the wires when the remote switch is open and it must be less than 25nF.

**Note:** Use table as a guide only, cable resistance may vary depending on the wire standard and construction.

Cable Size Square mm	Resistance in Ohms per 1000 Metres
0.2	95.30
0.5	36.20
0.75	24.13
1.0	18.10
1.5	12.10

# WIRING DIAGRAMS

## PLUG & PLAY CONNECTIONS

### PLUG AND LEAD WIRING

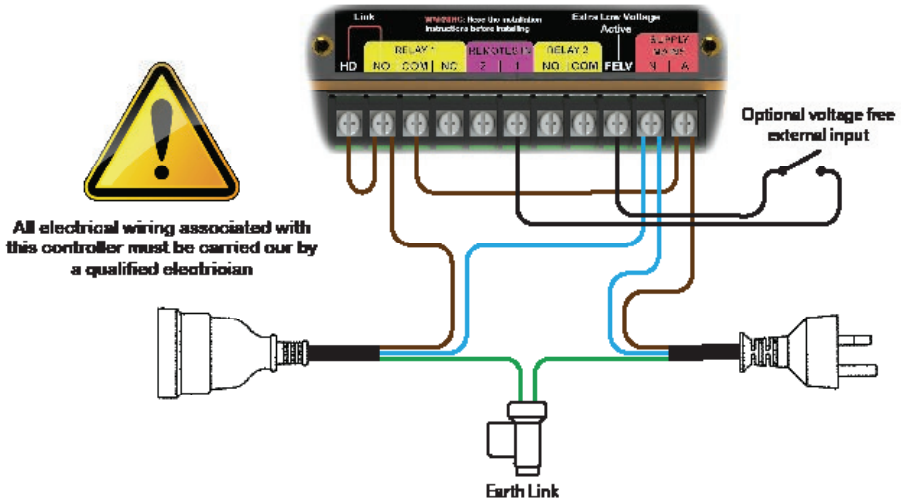

## CONNECTIONS FOR A SINGLE PHASE PUMP

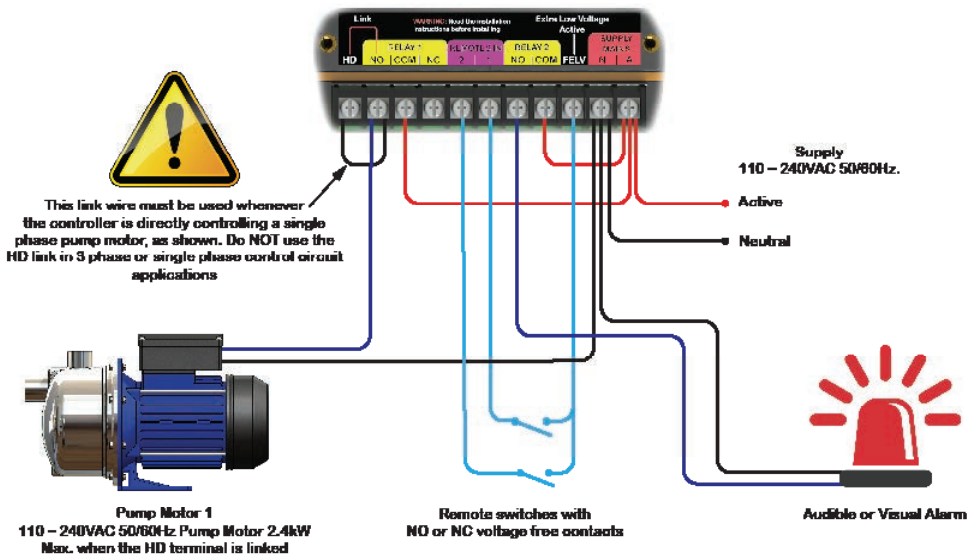

# DUAL SINGLE PHASE PUMPS & 2 REMOTE INPUTS

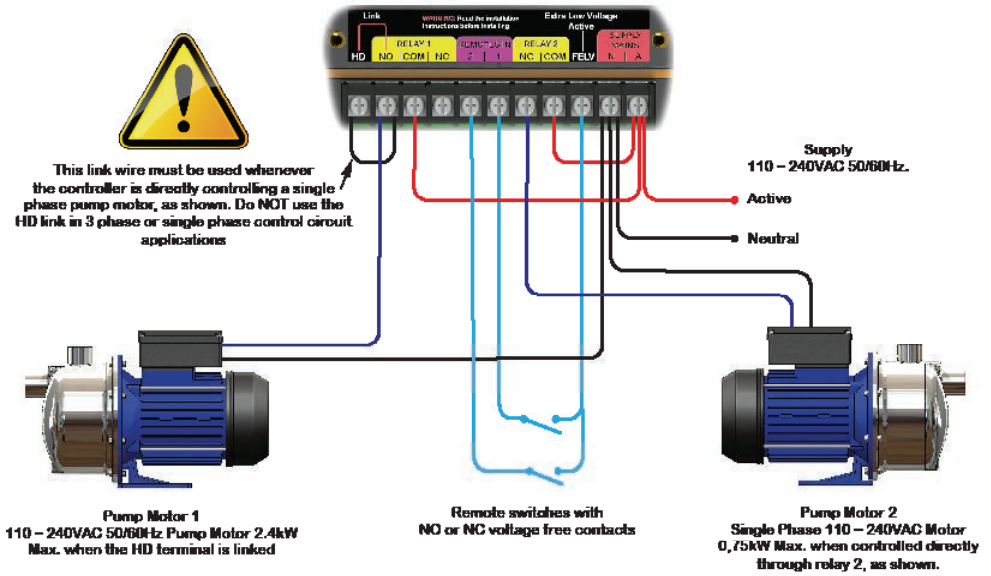

## LOW VOLTAGE SUPPLY

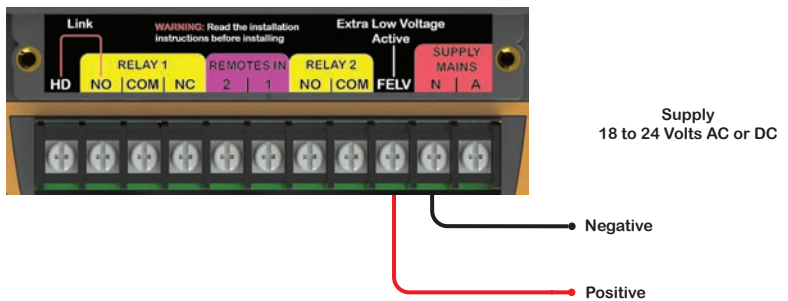

# BASIC 3 PHASE PUMP CONTROL

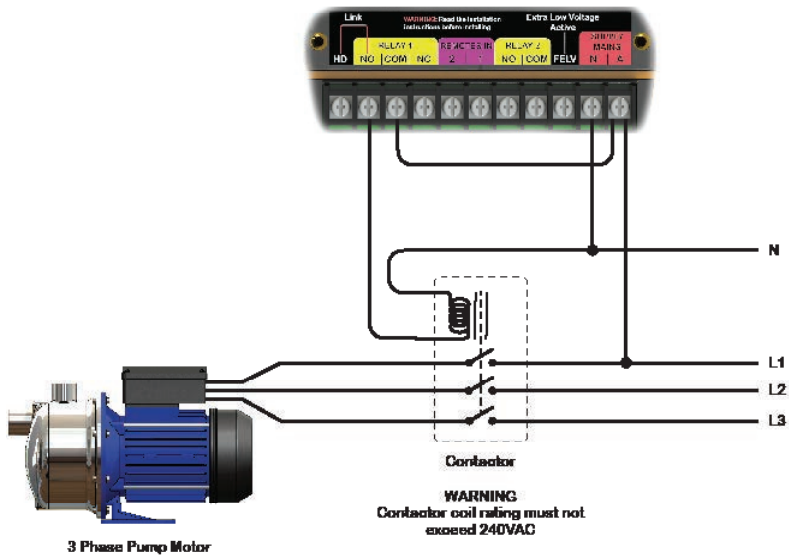

# DUAL 3 PHASE PUMP CONTROL

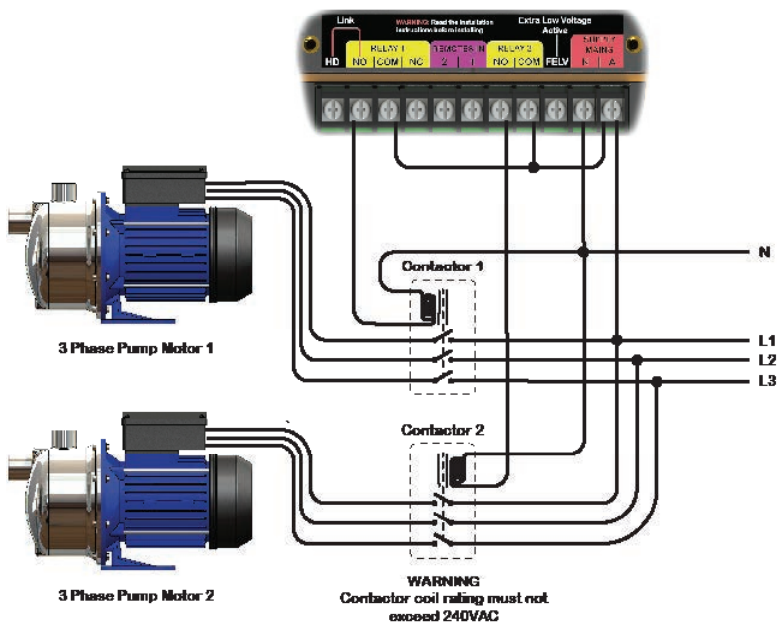

# 3 PHASE CONTROL WITH ALARM & REMOTE INPUT

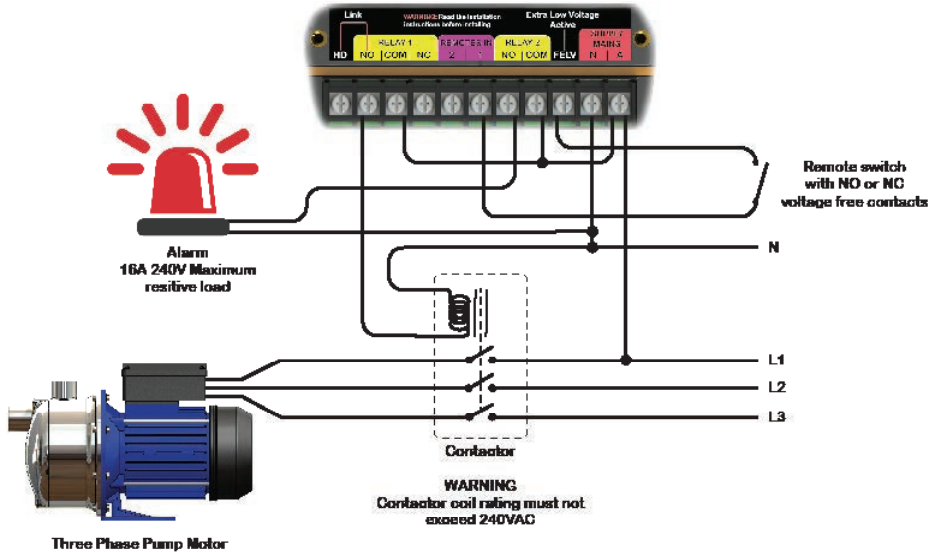

# THE 12VDC E30 DIGITAL PRESSURE SWITCH

A low voltage DC version of the E30 is available for battery operation and for use in solar pumping systems. Functionally the 12V DC model is the same as the mains voltage model except for the terminal block markings. On the 12VDC model the active and neutral terminals are replaced by a positive + and a negative – terminal. Supply voltage across the positive and negative terminals must never exceed 24VDC or the flow switch will be damaged. The supply terminals are reverse polarity protected, however, the E30 will simply not operate unless the supply polarity is correct.

## 12VDC REMOTE INPUT

If a remote switch is connected to the 12V DC E30, the supply to the remote switch must be taken from the positive terminal on the E30. The remote switch and its connecting circuit will then operate at 12VDC.

## 12VDC E30 CONTROLLING A SINGLE PHASE PUMP

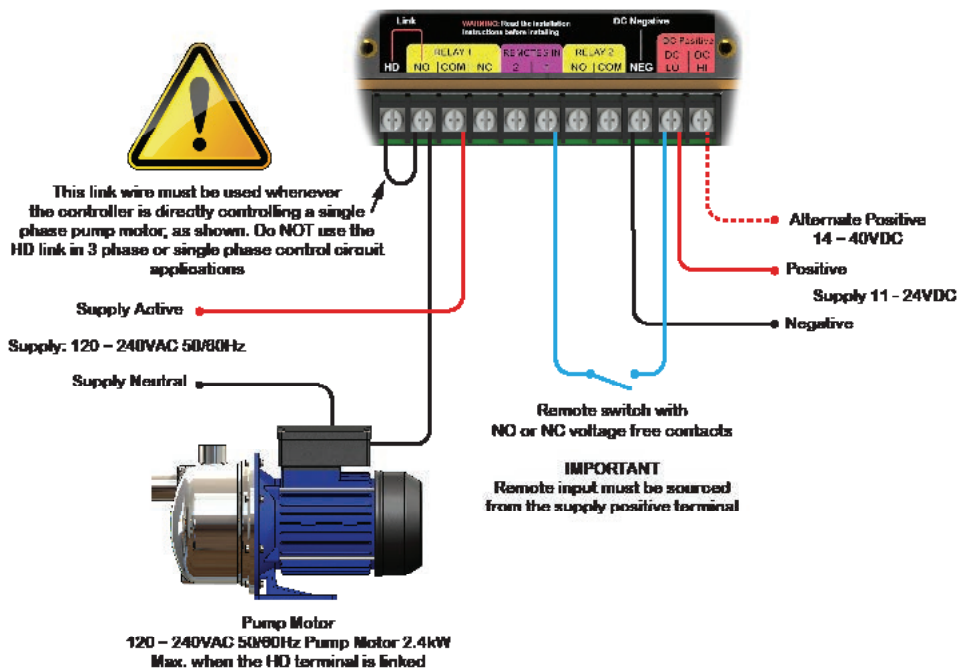

# PROGRAMMING THE E30 Mk2

For a description of the functions of the buttons and lights, please read pages 2 and 3 of this manual before proceeding.

## RESTORING FACTORY DEFAULTS (Purging the Settings)

Provided the E30 is unlocked, you can restore its default factory settings at any time by pressing and holding down the **(P)** button and pressing and then releasing the **(R)** button. Once the **(R)** button has been released, release the **(P)** button. The screen then displays **SETTINGS CLEARED PRESS P**. Doing this removes any settings you may have entered and restores the E30 to its default state.

## LOCKING & UNLOCKING THE E30 Mk2

The E30 is supplied by the factory in an unlocked state and can be programmed using its buttons. To prevent unauthorised personnel from altering its settings, the programming button **(P)** can be locked.

### LOCKING THE E30

To activate the lock, press and hold down the **(Λ)** and **(V)** buttons and then press and release the **(R)** button. Continue to hold the **(Λ)** and **(V)** buttons down until the screen displays **LOCK**. (takes about 2 seconds) release the **(Λ)** and **(V)** buttons. The E30 is now locked. When locked, pressing the **(P)** button will not allow access to the E30's menu, instead a message **PROGRAM LOCKED PRESS RESET** is displayed on the screen.

### UNLOCKING THE E30

To unlock the E30 repeat the above procedure, press and hold down the **(Λ)** and **(V)** buttons and then press and release the **(R)** button. Continue to hold the **(Λ)** and **(V)** buttons down until the screen displays **UNLOCKED**. (takes about 2 seconds) release the **(Λ)** and **(V)** buttons.



## GETTING STARTED

- 1) Use the least number of functions possible. Do not program in functions you do not specifically require, as to do so will make the system's operation unnecessarily complicated and may introduce unpredictable interactions between the various functions.
- 2) When changing modes always start by purging the previous settings to restore factory defaults before proceeding. This ensures no conflicts occur between previously set functions and new functions.
- 3) Set realistic and sensible values into the various functions. For example, do not set a pump to stop at a lower pressure than it is set to start at. Always set the E30's starting and stopping pressure differential to as wide a difference as possible.

The E30 can control a pump or pumps in a variety of ways. The functions are divided into sections called modes. In addition to the operating modes the E30 includes functions common to most modes and functions specific to individual modes.

**With the E30 powered up, Press the (P) button. Hold it down for 1 second and then release it.**

**KELCO [www.kelco.com.au](http://www.kelco.com.au)** This is the first screen in the menu

**Press and release (P) again.**

**PRESSURE SWITCH MODEL E30** Displays the model number

**Press and release (P) again.**

**VERSION 000000.** The version number must match the version number on the cover of this book.

**Press and release (P) again.**

**USE REMOTE 1 FOR START & STOP** Lets you configure remote input 1 for tank filling and similar applications.

**USE REMOTE 2 FOR REBOOTING** Lets you use a remote normally open switch to remotely reboot the E30 Mk2.

**Press and release (P) again.**

**SELECT PRESSURE UNITS: kPa.** Press and release the (v) button to change kPa to psi. Press the (^) button to change back to kPa.

**Press and release (P) again.**

**SELECT A MODE PRESS P**

## **SELECTING A SUITABLE OPERATING MODE**

Selecting a suitable operating mode is critical to the use of the E30. The mode you choose will depend on exactly what the pump system is required to do and how you want it controlled. Step through the modes by pressing the (▼) (▲) buttons. Highlight the mode you want to use and press and release (P) to lock it into the E30's memory and to advance to the next screen.

### **Mode 1 Pressure Switch**

*In mode 1 the E30 operates as a loss of prime pressure switch.* Mode 1 provides you with a start-up timer to allow time for the pump to start and for the system pressure to climb above whatever trip pressure you may enter. A run-on timer is also available so the E30 can ignore short term dips in pressure without tripping out on low pressure. *Mode 1 is commonly used to control pressure systems and provide loss of pressure protection to pumps.*

### **Mode 2 Pressure Guard**

*Mode 2 is used to protect systems against over and under pressure conditions.* Mode 2 allows you to set a high and low-pressure limit and a trip pressure. The pressure guard functions as a protection device for systems that are normally controlled by other means. In the event of a problem developing, mode 2 can override the systems normal control and shut the system down. *Mode 2 is commonly used to protect pumps and pipe systems against high and low-pressure extremes.*

### **Mode 3 Snap Action Pressure Switch**

*In mode 3 the E30 acts as a single point snap action pressure switch.* Mode 3 causes the E30's output relay to switch on and off on a very fine pressure differential. The set point is fully adjustable as is the precise difference between the on and off pressure points. *Mode 3 is suitable for general process control applications.*

### **Mode 4 Dual Pump Control**

The E30 can control 2 pumps simultaneously using its 2 output relays. The pumps operate independently in terms of their starting and stopping pressures. *Applications for mode 3 include duty and standby pump*

*sets, dual alternating pump sets and line pressurising systems.*

## **OPTIONAL FUNCTIONS**

Each mode includes optional functions enabling the E30 to be configured to a specific application. A detailed description of the functions follows. Some options are mode specific. *The relevant modes for each function are indicated by number in the functions heading.*

### **USE REMOTE 1 FOR START & STOP Modes 1 2 3**

A remote switch can be connected to the remote input terminal No 1, RMT1, of the E30. Use the (**v**) and (**^**) buttons to highlight YES or NO. Select YES if you are using a remote high / low tank level switch.

### **USE REMOTE 2 FOR REBOOTING Modes 1 2 3 4**

A remote switch with voltage free normally open contacts can be connected to the remote input terminal No 2, RMT2. Closing this switch causes the E30 to stop whatever it is doing and reboot. In effect it acts in the same way as pressing the red reset button on the E30. If the remote button is held closed the screen on the E30 displays **RELEASE THE RESET BUTTON**. The E30 will remain frozen until the remote switch opens. It will then reboot normally.

### **USE ALARM RELAY Modes 1 2**

The E30 includes 2 output relays. Relay one is normally used for pump control. Relay 2 can be used as an alarm relay or to control a second pump. If you select yes to this question you are presented with the first option in a list of ways the alarm relay can be configured. Use the (**v**) and (**^**) buttons to step through the list. Press and release the (**P**) button once you have highlighted the option you want to use.

**CLOSED AT HI-LO PRESSURE LIMITS** In mode 1, closes the alarm relay contacts when pressure reaches the high or low set points.

**CLOSED IF PUMP IS OFF** Relay 2 is closed while the pump is off, provided the E30 is powered.

**CLOSED IF PUMP IS ON** Relay 2 is closed while the pump is on, provided the E30 is powered.

**CLOSED ONLY ON A HI PRESS FAULT** Relay 2 is closed if the E30 stops

because of over pressure.

**CLOSED ONLY ON A LO PRESS FAULT** Relay 2 is closed if the E30 stops because of under pressure.

**CLOSED ONLY WHEN BATCH COMPLETE** When using the batching function, relay closes when the batch is complete.

**STARTS PER HOUR SETTING EXCEEDED** If you select the anti-cycling feature from the menu and the pump shuts down because the number of starts per hour has been exceeded, relay 2 will close its contacts.

**ON IF PRESSURE IS TOO LOW** In mode 2 only, closes the alarm relay on low pressure.

**CLOSED DURING PRE-START DELAY** Relay 2 can be used to run peripheral equipment such as mixers prior to the pump starting. Relay 2 opens when the pre-start timer times out and turns off the peripheral device.

**CLOSED IF PUMP RUNS DRY** In mode 1 if the trip pressure is being used and pressure is lower than the trip setting and times out on the pressure dip timer, pump is shut down and displays “pump ran dry”. In this scenario the alarm relay is also closed if you have selected this alarm option.

## **PRE-START DELAY TIMER Modes 1 2 4**

The pre-start delay timer delays the starting of the pump for a settable period. It can be used to allow peripheral equipment to operate prior to a pump starting. For example to allow a mixer to operate prior to starting a pump. It can also be used to sequence or stage the starting of multiple pumps in sequential or cascaded transfer pumping systems. Starting pumps sequentially rather than all at once in such systems greatly reduces the current draw on the power supply and ensures each pump spins up to full speed before the following pump starts. The delay can be set from zero to 64800 seconds (18 hours) in one second increments. The count increments up in 60 second steps and down in 1 second steps.

## **START-UP TIMER Modes 1 2 4**

The E30 includes a start-up timer. The purpose of the start-up timer is to ignore any initial lack of pressure and allow time for the system pressure to rise above your set trip pressure before imposing any pressure limits on the pump's operation. The start-up timer can be adjusted from 1 second to 900 seconds in increments of 1 second. The start-up timer automatically terminates its run as soon as a pressure higher than the set starting

pressure is detected. The start-up timer is factory set to 5 seconds. It can be set between 1 second and 900 seconds using the (v) and (^) buttons.

## **RUN-ON TIMER Modes 1 2**

The E30 includes a run-on timer that can be set from 1 second to 900 seconds in increments of 1 second. The purpose of the run-on timer is to allow the E30 time to tolerate momentary dips in pressure that would otherwise cause the shutdown of the pump. You can choose not to use the run-on timer by setting its time to zero. If you do this then the instant the E30 detects a pressure less than its trip pressure the pump will be shut down.

## **DELAYED RESTART Mode 1**

If you choose to use delayed restart and press (P) you will be asked for a delay time in hours and then in minutes. The range of adjustment is 1 minute to 99 hours 59 minutes in increments of 1 minute.

The purpose of the delayed restart is to prevent the pump from restarting once it has stopped on high pressure. As an example, if the pump system was being used to fill a tank that had a float valve fitted to it and the valve closed then the system pressure would rise and the E30 would shut the pump down once the pressure reached your high-pressure cut-out point. Ordinarily, if the float valve leaked or opened, the pressure would fall and the E30 would start the pump as soon as the pressure reached your set cut-in pressure. The delayed restart function can be used to delay the restarting of the pump. The delay may be to prevent the pump from hunting on and off or it may be to allow time for the water level in the tank to drop some distance before allowing the pump to restart. If you select yes to this function and enter a suitable delay, the question that follows asks: -

## **AUTO START AFTER DELAY**

Selecting yes to this question means the pump will only restart when conditions are suitable, for example in mode 1 when the system pressure is below the set cut-out pressure. In this situation, the pump would not normally start until the pressure fell to below the set starting pressure. Auto start after delay overrides this and instantly starts the pump. Selecting off to this question means that after the delay period the pump will only start under conditions it would normally start under. For example, in mode 1 it will only start when pressure falls to below the normal set starting pressure.

## **AUTO RESTART IF RUN DRY Mode 1**

The E30 will identify a dry run situation as a loss of pressure. If the pump shuts down because it has run dry, it can be set to try to restart using the auto restart function after a settable delay. The range of the delay is 1 minute to 99 hours 59 minutes in one minute increments.

**SINGLE RESTART ON A FAULT YES.** Select this option if you want the pump to try to restart one time only.

**REPEATED RESTARTS ON A FAULT YES.** Select this option if you want the pump to repeatedly try to restart after the delay period.

## **BATCH CONTROLLER Mode 1**

If you choose to use auto restart as described previously, the E30's batch controller will not appear in the menu. To use the batch controller, you must first have set auto restart to off. The batch controller and auto restart functions conflict so the E30's menu prevents you from selecting both functions. The batch running time can be set from 1 minute to 99 hours 59 minutes in one minute increments.

The batch controller allows you to have the pump run for a set period and to then automatically shut down. An example of its use would be to pump X hours of water to a tank and then have the pump shut down. Pressing the **(R)** button will then repeat this process.

## **TRIP PRESSURE Mode 1**

The trip pressure can be set to any value from 0 to 2000 kPa or from 0 to 290 psi. The trip pressure must be set to some value that is less than the start pressure. If the system pressure falls to below the set trip pressure, it is the trip point that invokes the run-on timer and ultimately shuts the pump down if pressure fails to recover. If you choose not to use the trip pressure and leave it set to zero then the E30 reverts to operating like a basic pressure switch. Its contacts will remain closed at all pressures that are less than your set high pressure cut-out. If no pressure is present in the system the contacts of relay 1 will be closed. No loss of pressure protection will be provided by the E30 if it is set up this way.

## **START PRESSURE Mode 1**

The start pressure can be set to any value from 1 kPa to 2000 kPa or from 1 psi to 290 psi in increments of 1 kPa or 1 psi. Normally the start pressure will be set to the pressure at which you want the pump to start. In normal operation, each time pressure drops to whatever value you have set, the pump will start. Once running the pressure can fall to below the value you have set and the pump will continue to run. In fact, if you have not set the trip pressure to some value greater than zero, the pump will continue to run despite a complete lack of pressure. The start pressure can be set as low as 1 kPa or 1 psi and the E30 will function in the manner described. If you choose to set the start pressure to zero you will invoke a warning message from the E30 to check your pressure settings. The E30 will not tolerate having its start pressure set to zero, in addition the start pressure must always be set to a higher pressure than the trip pressure.

## **STOP PRESSURE Mode 1**

The stop pressure is the pressure at which the E30 will shut down the pump in normal operation. It must be set to some value that is higher than start and trip pressures. The range of adjustment is 0 to 2000 kPa or 0 to 290 psi in increments of 1 kPa or 1 psi. If you attempt to set the stop pressure to a value that is less than the start or trip pressures you will invoke a warning message from the E30 to check your pressure settings.

## **HIGH PRESSURE RUN-ON Mode 1**

If you set high pressure run-on to “YES” (ON) the question that follows asks you to enter a time limit that the pump can operate above the normal stop pressure. When operating a high volume centrifugal pump that exhibits a relatively small pressure change across a wide range of flow (a flat Q-H curve) the high pressure run-on can prevent the pump from cycling on and off on a low draw off by establishing a high pressure zone rather than a fixed stopping pressure. Within the defined pressure zone and for a limited time the pump can be allowed to continue to run thus preventing the pump from cycling on and off on a low discharge flow.

***WARNING: Never apply this function to a helical rotor pump or to any positive displacement pump. Helical rotor pumps and PD pumps in general may be damaged by incorrect application of this function.***

***Take great care in using the high pressure run-on and its associated settings. Always set the high pressure limit to a pressure that is well below the pumps shut off head. Keep the high pressure run-on time to a minimum to avoid overheating the pump due to recirculation.***

## **HIGH PRESSURE RUN-ON (Time)**

If you previously set high pressure run-on to YES (ON), the question that follows asks you to set a run-on time. The time can be set from 0 to 900 seconds. The time you set will be the maximum time the pump can operate for above its normal stop pressure. The high pressure run-on timer is self terminating and terminates its run if pressure drops below the normal stop pressure.

## **HIGH PRESSURE LIMIT**

The high pressure limit is the absolute highest pressure the system can operate at. It must be set to a pressure higher than the previously set stop pressure. The available range is 0 to 2000kPa or 0 to 290 psi. If the high pressure limit is set to a pressure less than the normal stop pressure an error message is invoked advising you to check the pressures.

On a rising pressure the E30 will start the high pressure run-on timer as soon as it detects pressure higher than the normal stop pressure. The high pressure run-on timer will run for whatever you set it to and expect pressure to fall back below the normal stop pressure before it times out. If the high pressure run-on timer times out, it shuts the pump down and reverts to a normal waiting state. The pump will not then start until pressure falls to below the set starting pressure. Given pressure falls to below the set stop pressure before the high pressure run-on timer times out, the pump will stop and wait for pressure to fall to the set starting pressure.

In effect the high pressure run-on and its associated pressure setting create a shut down pressure band rather than a single shut down point. The pump can continue to operate on a low draw off while in this band for a set period of time using the high pressure run-on timer.



## **ANTI-CYCLING Mode 1**

Electric motors are often limited in the number of times they can be safely started in any one hour. This is particularly important in the operation of submersible bore pumps. When a motor starts there is an initial inrush of current that produces heat in the coils and iron rotor of the motor. If the frequency of starts is excessive the accumulation of heat within the motor can cause severe damage and eventual failure of the motor. Submersible bore pump motors are particularly prone to damage from excessive cycling

### **MAXIMUM STARTS PER HOUR**

The anti-cycling option built into the E30 allows the user to set the maximum number of times the pump can be safely started in any one hour period. If you select yes to this option the screen that follows will ask you to enter the maximum number of times the pump can be started in any one hour. The number of starts can be set from 1 start per hour to 1800 starts per hour. Please contact your pump supplier to obtain the correct figure for your specific pump. In operation, the anti-cycling system monitors both time and the number of starts and compares the two. If the starts per hour rate is exceeded for a settable number of consecutive times in any one hour period the pump will be automatically shut down and the controller will display a message indicating the starts per hour rate was exceeded.

### **NUMBER OF STARTS IN SEQUENCE**

After setting the required number of starts per hour and pressing **(P)** you are asked how many starts in a row you are prepared to accept. The default setting is 5 starts. This can be adjusted between 2 and 50 starts. Assuming you accept the default of 5 sequential starts then as a simple example of the way the anti-cycling system works, if starts per hour rate is set to 360 (one start every 10 seconds maximum) and the pump started 4 times in a row at less than 10 seconds between each start and then did not start again for 12 seconds the anti-cycling shutdown will not be invoked. If, however, the pump started 5 times in a row with less than 10 seconds between the starts the anti-cycling system would be invoked and the pump would be shut down. In a conventional pressure system, the anti-cycling function can be used to protect the pump from damage in the event of the system's air cell losing its air charge. If air is lost from a system's air cell due to a ruptured diaphragm or leaking air valve, the pump will hunt on and off rapidly. Such rapid cycling will cause the pump to overheat very quickly.

## **LOW-PRESSURE TRIP Mode 2**

The low-pressure trip point can be set to any value from zero to 2000 kPa or from zero to 290 psi. The low-pressure trip point must be set to some value that is less than the high-pressure trip point. If you attempt to set the low-pressure trip point to a pressure that is greater than the high-pressure trip point you will invoke a warning from the E30 alerting you to the problem. If the pressure falls to below the low-pressure trip point, it is the trip pressure that invokes the run-on timer and ultimately shuts the system down if pressure fails to rise above its set point by the end of the run-on period. The trip pressure will normally be set to some value that is well below the high-pressure trip point setting.

## **HIGH-PRESSURE TRIP Mode 2**

The high-pressure trip point can be set to any required value above the low-pressure trip point. The range of adjustment is zero to 2000 kPa or 0 to 290 psi in increments of 1 kPa or 1 psi depending on the pressure units you have chosen to use. The high-pressure trip point will ordinarily be set to some value that is well above the low-pressure trip point. If you attempt to set the high-pressure trip point to a pressure that is lower than the low-pressure trip point, you will invoke a pressure warning from the E30 to check your pressure settings. If the system pressure rises to above the high-pressure trip point the E30 will immediately shut down the system and close its alarm relay contacts and display a message to the effect that the pressure is too high.

If you choose not to use the high-pressure trip point and leave it set to 0 the E30 reverts to providing low-pressure protection only for the system. When set up this way the E30 will start the system using its start-up timer and will expect to see the system pressure rise to above whatever low-pressure trip point you have set, before the start-up timer times out. Once above the low-pressure trip point the E30 will run the system without any regard to a high-pressure limit. If the pressure falls to below your low-pressure trip point the E30 will run its run-on timer and if pressure fails to rise above the low-pressure trip point by the end of the run-on, the E30 will shut the system down and display a message that the system pressure is too low.

When operated in the mode described above the E30 does not provide any high-pressure trip point. However, the E30 has an operating pressure

range that is limited to 2000 kPa or 290 psi. If the system pressure exceeds this limit for any reason and reaches 2200 kPa or 430 psi the E30 will automatically shut down the system and display a message that its 22 Bar excess pressure limit has been exceeded. The 22 Bar, 2200 kPa, 430 psi limit is not adjustable and is intended to protect the E30's built in pressure sensor against excess pressure.

### **SET PRESSURE Mode 3**

The set or snap pressure is the pressure at which the switch will change state from on to off or from off to on, depending on how you have configured the relay's contacts. Enter your required set pressure in the range 7 to 2000 kPa or 1 to 290 psi. Press the **(P)** button to record your setting and move to the next screen.

### **DELTA PRESSURE Mode 3**

Delta pressure is the differential pressure between the set on and off pressures. The range of adjustment is 7 to 140 kPa or 1 to 20 psi in increments of 7 kPa or 1 psi. The higher the value you enter the more stable and tolerant the switch will become to minor pressure fluctuations.

### **ALTERNATE THE PUMPS Mode 4**

Select NO if you want the 2 pumps to operate in a duty / standby configuration. Select YES if you want the 2 pumps to operate alternately.

### **ALTERNATE PUMPS EVERY 000 STARTS**

The maximum frequency of alternation is 2. Meaning every second start will be the second pump. It means pump one will start first and when it stops the next pump start will be the second pump. When pump two stops, the next pump to start will again be pump one. The frequency of alternation can be set between 2 and 240 starts. If you choose a high number it means pump two will start and stop less frequently. For example, if you set the frequency to 100, it means pump one will start and stop 99 times before pump two starts and stops once. In duty and standby pump sets, a high starting frequency number can be used as an anti-seizing strategy. Pump one operates most of the time and occasionally pump two operates once, just to ensure lack of use has not resulted in it seizing.

The LCD display on the E30 shows which pump is running at any given

time. It also displays a countdown “Alt xxx” in the bottom right corner of the screen indicating a countdown of the pump alternations. The count starts at whatever number was entered for alternations and reduces by one each time the pump stops. When the count reaches zero the second pump starts. When the second pump stops the count resets to the original alternation number. By observing the count, it is possible to assess at a glance when pump 2 will start.

### **SET LOW PRESSURE TRIP POINT Mode 4**

The trip pressure can be set to any value from 0 to 2000 kPa or from 0 to 290 psi. The trip pressure must be set to some value that is less than the start pressure of either of the two pumps. If either or both pumps are running and the system pressure falls to below the trip pressure, it is the trip point pressure that invokes the pressure dip timer. It ultimately shuts the pump or pumps down if pressure fails to rise above the trip pressure by the end of the dip timer run-on period.

If you choose not to use the trip pressure or leave it set to zero then the E30 may not provide dry run protection. The trip pressure can be set as low as 1 kPa or 1 psi and it will provide loss of pressure protection to a pumping system, however, it is important to remember that if it is set to zero no low-pressure protection will be provided by the E30.

### **PRESSURE DIP TIMER Mode 4**

If you elect to use the low-pressure trip point and set a suitable trip pressure, the question that follows asks you to set a dip pressure time. The dip pressure time is the time the E30 will tolerate the pressure being below the low-pressure trip point before shutting the pump or pumps down. The dip timer is factory set to 5 seconds. This can be altered using the (v) and (^) buttons. The range of adjustment is 1 second to 900 seconds in 1 second increments. When setting the dip time, be aware that the pump or pumps may be running dry during the dip period. The dip timer automatically terminates its run and the E30 returns to normal running as soon as pressure higher than the trip pressure is detected. If the system pressure remains low and the dip timer times out, both pumps will be shut down and the E30 will display a warning message that the pressure is too low.

## **SET THE PRESSURE PUMP 1 Mode 4**

The E30 menu asks you to set the required operating pressures for each pump starting with pump one. Pump one will be the pump controlled by relay 1 in the E30. The pressures you set will depend on the application. Generally, pump one should be considered the main pump. In a line boosting or jockey pump application pump one will be the largest capacity pump and will provide the bulk of the system's output. In such a system pump one would normally be set so there was a reasonably wide difference between its starting and stopping pressures.

### **START PRESSURE 1**

The starting pressure can be set between 0 and 2000 kPa or between 0 and 290 psi. If you elected to use a low-pressure trip point, the starting pressure must be higher than the set trip pressure.

### **STOP PRESSURE 1**

The high-pressure cut-out must be set to a value that is higher than the cut-in pressure and if used, the trip pressure. Normally the high-pressure cut-out will be a value considerably higher than the cut-in pressure as to some extent it is the difference between the cut-in and cut-out pressures, relative to draw off, that will determine how often the system will cycle on and off. If you attempt to set an unrealistic pressure such as a cut-out pressure that is lower than the cut-in pressure then on pressing **(P)** a warning screen appears asking you to review the pressure settings. Pressing **(P)** then takes you back to the top of the menu.

## **SET THE PRESSURE PUMP 2 Mode 4**

The starting and stopping pressure you set for pump two will depend on the application. If the system is to operate as a duty standby set then in most situations the pressure settings for pump two will be identical to the settings used for pump one.

### **START PRESSURE 2**

The starting pressure can be set between 0 and 2000 kPa or between 0 and 290 psi. If you elected to use a low-pressure trip point, the starting pressure must be higher than the set trip pressure.

## STOP PRESSURE 2

The stopping pressure can be set between 0 and 2000 kPa or between 0 and 290 psi. The cut-out pressure must be set to a value that is higher than the cut-in pressure and if used, the trip pressure.

## ACCEPT SETTINGS Modes 1 2 3 4

This is the end of the menu. Select yes to confirm all your previous settings or use the (V) (Λ) buttons to select no to return to the top of the menu. If you accept yes and press (P) you are then asked to press (R) to start the pump. The F60 will start the pump and attempt to run the system using the settings you have programmed in. If the settings you have initially made prove unsatisfactory then simply pressing and holding down the (P) button for about 1 second and then releasing it will shut the pump down and take you to the top of the main menu where you can step through the settings and make appropriate changes.

## MAINTENANCE

The E30 is a minimal maintenance device. If it is correctly installed in a location that is out of direct exposure to the elements it should give a long and reliable life and require no maintenance at all. Factors that may reduce its life are lightning strikes or power surges, failure to fully tighten its lid and cable glands, exposure to pressures or temperatures in excess of its ratings and operation outside its electrical limitations in terms of supply voltage and motor loads.

## WARRANTY

The E30 Mk2 is warranted against faulty workmanship and materials for a period of 12 months from the date of purchase. Our complete warranty statement can be downloaded from: -

<http://www.kelco.com.au/menu/information/warranty-statement>

If a warranty issue arises with this product contact your supplier or Kelco Engineering Pty Ltd. You will be issued with a returns goods authorisation number. The RGA number and proof of purchase must accompany any goods returned to us under warranty.



**If the E30 pressure switch is used in a manner not specified by the manufacturer the pump protection provided by the switch may be impaired or negated. In addition, all warranties stated or implied may be rendered invalid.**

Designed and Manufactured in Australia by

## **KELCO Engineering Pty Ltd**

A.B.N. 20 002 834 844

Head Office and Factory: 9/9 Powells Road Brookvale 2100 Australia

Postal Address: PO Box 7485 Warringah Mall NSW 2100

Phone: +61 2 99056425 Fax: +61 2 99056420 Email: [sales@kelco.com.au](mailto:sales@kelco.com.au)

Web: [www.kelco.com.au](http://www.kelco.com.au)

**PLEASE NOTE:** Kelco Engineering Pty Ltd reserves the right to change the specification of this product without notice. Kelco Engineering Pty Ltd accepts no liability for personal injury or economic loss as a consequence of the use of this product. All rights reserved copyright Kelco Engineering Pty Ltd © 2018