

# KELCO

## MF20 Series Micro Flow Switch

### Features

- Detects flows less than 350mL /Hour
- Suits tube sizes 6 to 20mm (1/4" to 3/4") DIA
- No metal parts in contact with the liquid
- Suits pulsed or continuous flows
- 18 BAR (260 PSI) Pressure rating
- Stable electrical response
- Very high flow through
- Very low head loss
- Vertical mounting
- Easy to install

### Applications

- Control for backup dosing pumps
- Chemical metering pump control
- Chemical injection point status
- Laboratory applications
- Loss of prime detection
- Batch control

### Outline

The MF20 micro flow switches are a super sensitive version of our popular P20 inline flow switch. The MF20 is a very simple and reliable mechanical flow switch that can detect extremely low flows. The switch can detect either continuous or pulsed flows. Typical applications include monitoring chemical metering pumps to ensure they are delivering flow, in water treatment, cooling towers and in a multitude of industrial processes.

The MF20 flow switch gives a simple On or Off response to liquid flow. There are no metal parts in contact with liquids within the switch, so the MF20 is ideal for use in aggressive media such as acids and alkalis and many chemical solutions. The standard switch is supplied complete with tube flare fittings, for 3 popular tube sizes, and a set of pipe spigots and unions, for direct fitting into 15NB PVC or ABS pipe work. In addition, a three electrical options are available.

### Construction

The MF20 micro flow switches are made from glass-reinforced polypropylene with Viton O-ring seals and PVC spigots. These are the only materials that come in contact with liquids passing through the switch. A high power rare earth magnet operating through the solid body of the switch actuates the MF20 electrically.

The electrical housing is weatherproof to IP67, and is supplied with an integral 20mm cable gland, for conduit or cable entry. The electrical circuit boards used in the switch are interchangeable, and spare part kits are available for most components.



### Operating Parameters

The body of the MF20 flow switch houses a fluted piston. Any flow, either pulsed or continuous, causes the piston to be lifted up within the switch body to a point where the liquid can pass over the piston and out of the top of the switch. The piston contains a magnet that actuates a reed switch and this provides the switching output. When flow stops, the piston sinks due to gravity, thus moving the magnet within away from the reed switch.

No metal parts are in contact with the process liquid, and the simple gravity return system provides an exceptionally reliable corrosion proof mechanism. The sensitivity of the flow switch is determined by the viscosity of the fluid and by the clearance between the piston and the switch body. Three pistons are supplied with each MF20 flow switch, with accurate and predictable switch points ranging from 0.32 litres per hour to 12.8 litres per hour. The MF20 flow switch must be mounted vertically with flow upward through the switch body. The switch can be mounted directly on the suction or discharge valve of a metering pump.

# MF20 SERIES DATA

## Flow Sensitivity

Sensitivity to fluid flow is a function of liquid viscosity and piston clearance. There are 3 pistons supplied with the MF20 flow switches. Each piston has a distinct switching point. The pistons are designated and marked A, B and C. The "A" piston is fitted to the MF20 flow switches as standard. The optional "B" and "C" pistons are also supplied packed in with each switch. The table below sets out the performance parameters of the 3 pistons.

The data is based on testing with water at 15°C as the test medium, and is accurate to +/-10%. Changes in liquid viscosity or temperature will affect the switching point. Increases in viscosity will proportionally decrease the flow rate required to actuate the switch, and will proportionally increase the response time. Decreasing viscosity will proportionally increase the flow rate required to actuate the switch, and will proportionally decrease the response time.

Note: In pulsed flow applications where no pulse dampener is installed, and the pulse frequency is less than the electrical response time, the MF20 flow switch may respond with a train of on / off pulses rather than with a continuous on signal.

Data in the table below refers to the MF20-B and MF20-R models only. The MF20-C flow switch is less sensitive to flow. The flow required to actuate and de-actuate the MF20-C is twice as high as the values given in the table.

Piston Markings and Designation	Switching Point on a Rising Flow In Litres Per Hour	Switching Point on a Reducing Flow in Litres Per Hour	Electrical Response Time in Seconds on Cessation of Flow
A	0.32 +/- 15%	0.30 +/- 15%	4
B	3.10 +/- 15%	3.05 +/- 15%	3
C	12.8 +/- 15%	12.6 +/- 15%	2

The graph below shows the dynamic head loss across the MF20 flow switch. The data refers to water at 15°C as the test medium.

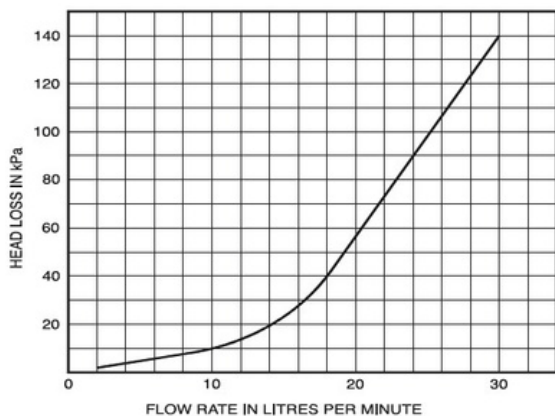

## Electrical Data

The MF20 inline flow switch is available in a variety of electrical configurations, to suit specific applications. The model numbers and details of these options are outlined in the table below.

SWITCH MODEL	MODULE TYPE	CONTACT CONFIGURATION	SWITCHED POWER MAXIMUM	SWITCHED VOLTAGE MAXIMUM	SWITCHED CURRENT RESISTIVE AC (RMS) MAXIMUM	INDUCTIVE LOADS (POWER FACTOR 0.4)	TYPICAL APPLICATION
MF20-B	Dry Reed Switch	S.P.S.T N.O	40 Watts	240V AC 200V DC	1 Amp	Not Suitable	PLC and General Control Circuits
MF20-C	Dry Reed Switch	S.P.D.T	20 Watts	140V AC 150V DC	1 Amp	Not Suitable	PLC and General Control Circuits
MF20-R	Solid State Relay (Triac)	S.P.S.T N.O	740 Watts	2 to 240V AC	4 Amp Continuous (Spike to 15A)	4A at 240V AC 5A at 30V DC	AC Control Circuits and AC Motor Control

Note: The MF20 flow switch uses reed switches as the primary switching element. Reed switches are one of the most reliable mechanical switching devices ever devised. They offer an operating life in excess of 100 million cycles, however, care needs to be taken to ensure they are not electrically overloaded or if applied in questionable applications, suitable protection should be added to the control circuit.

## Chemical Compatibility

The MF20 micro flow switch is constructed from glass reinforced Polypropylene with Viton O-ring seals. Specific data on the chemical compatibility of Polypropylene and Viton can be obtained from widely available chemical compatibility charts, or from Kelco, on request.

**IMPORTANT : Never use this flow switch with the following reagents.**

- 1) Sodium Hypochlorite at >10% concentration.
- 2) Ferrous or Ferric solutions (Ferric Chloride etc.)
- 3) Solvents or hydrocarbon or alcohol solutions of any kind.
- 4) Sulphuric Acid at >50% concentration.
- 5) Nitric Acid > 20% concentration

## Dimensions

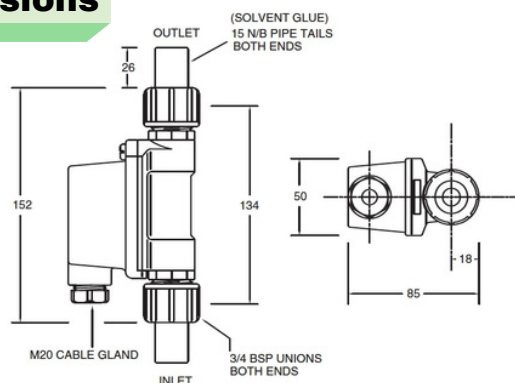

## Operating Limitations

Maximum recommended operating pressure (Static or Dynamic) at ambient temperature	1800 kPa (260 psi)
Minimum burst pressure at ambient temperature	9700 kPa (1400 psi)
Maximum liquid temperature	60°C at a pressure of 1 Bar absolute (see note below)
Minimum liquid temperature	-30°C
Maximum recommended continuous flow rate (water)	25Litres per minute (Head loss across the switch <100kPa at 25L/min)
Liquid pH range	1 to 14
Ingress Protection rating (Weatherproof rating)	IP67

**Note:** Temperature for the maximum operating pressure shown in the above operating environment table is 15°C. In the interest of safety, maximum operating pressure must be de-rated linearly in direct proportion to temperature increase, to a maximum pressure of 1 bar absolute at 60 degrees Centigrade. In other words only use this switch at elevated temperatures in non pressurised systems that are totally open to atmosphere in all circumstances and under all conditions.

## Kelco Engineering Pty Ltd

ABN 20 002 834 844

Head Office & Factory  
9/9 Powells Road,  
Brookvale 2100 NSW Australia

Postal Address  
PO Box 7485 Warringah Mall  
Brookvale 2100 NSW Australia

Phone: +61 2 99056425  
Fax: +61 2 9905 6420

Email: Sales@kelco.com.au  
Web: www.Kelco.com.au

PLEASE NOTE: Kelco Engineering Pty Ltd reserves the right to change the specification of this product without notice. Users will use their own judgment to determine the appropriateness of using Kelco Products in an application, any safety measures required and that the product is properly installed for that application. To the extent permitted by law Kelco Engineering Pty Ltd disclaims and excludes all and any liability for the use of this product in any particular application or for defective installation. Kelco switches are warranted against malfunction by a 12 month return to base manufacturer's warranty. Full details of our warranty and limitation of liability can be found in this document or downloaded from: <http://www.kelco.com.au/warranty>

All rights reserved copyright Kelco Engineering Pty Ltd © 2022