

INSTALLING AND OPERATING THE KELCO MF20 SERIES MICRO FLOW SWITCH



WARNING



Please read these installation and operating instructions fully and carefully before installing or servicing this Flow Switch. The MF20 Series flow switch is a mains voltage device. Death or serious injury may result if this switch is not correctly installed and operated. All electrical work on this switch must be performed by a fully qualified and licenced Electrician.

OUTLINE

The MF20 micro flow switch is a vertically mounted in line piston flow switch that is supplied preset to switch on or off at a specific flow rate. The body of the switch contains a piston that obstructs the line of flow. The process fluid, either a liquid or a gas enters the bottom of the switch and must push the piston up until it can flow over the piston and out the top of the switch. When the piston is pushed up by flowing fluid, a magnet inside the piston actuates a reed switch in the electrical enclosure; this provides a set of closed, (or open) electrical contacts that can be used in control circuits, to indicate flow. When flow stops the piston sinks down, due to gravity and in doing so, moves the magnet out of proximity of the reed switch, thus de-actuating the reed switch.

ENVIRONMENTAL LIMITATIONS

The MF20 micro flow switch has no metal parts in contact with the process fluid. Inert thermoplastics are all that come in contact with the liquid passing through the switch. The MF20 flow switch contains a close fitting piston, and should only be used in applications where the process fluid is reasonably clean and free of entrained or suspended material. Fluids containing large particulate matter, ferrous materials or fibrous matter should not be used in this switch. If the degree of contamination of the process fluid can't be guaranteed, then suitable line filtration should be fitted to the system downstream of the MF20 flow switch. The principle environmental limitations of the MF20 micro flow switch are set out in the following table.

Maximum recommended operating pressure (Static or Dynamic) at ambient temperature	1800 kPa (260 psi)
Minimum burst pressure at ambient temperature	9700 kPa (1400 psi)
Maximum liquid temperature	60°C at a pressure of 1 Bar absolute (see note below)
Minimum liquid temperature	-30°C
Maximum recommended continuous flow rate (water)	25Litres per minute (Head loss across the switch <100kPa at 25L/min)
Liquid pH range	1 to 14
Ingress Protection rating (Weatherproof rating)	IP67

IMPORTANT NOTE: Temperature for the maximum operating pressure shown in the above operating environment table is 15°C. In the interest of safety, maximum operating pressure must be de-rated linearly in direct proportion to temperature increase, to a maximum pressure of 1 bar absolute at 80 degrees Centigrade. In other words only use this switch at elevated temperatures in non pressurised systems that are totally open to atmosphere in all circumstances and under all conditions.

CHEMICAL COMPATIBILITY

The MF20 micro flow switch is constructed from glass reinforced Polypropylene with Viton O-ring seals. Specific data on the chemical compatibility of Polypropylene and Viton can be obtained from widely available chemical compatibility charts, or from Kelco, on request.

IMPORTANT : Never use this flow switch with the following reagents.

- 1) Sodium Hypochlorite at >10% concentration.
- 2) Ferrous or Ferric solutions (Ferric Chloride etc.)
- 3) Solvents or hydrocarbon or alcohol solutions of any kind.
- 4) Sulphuric Acid at >50% concentration.
- 5) Nitric Acid > 20% concentration

MECHANICAL INSTALLATION

The MF20 micro flow switch must be mounted vertically in the pipe work, with flow passing upward through the switch body. There is a direction of flow arrow on the switch body; this directionality must be adhered to, as the switch will not operate against a reversed flow. A comprehensive selection of pipe spigots and tube flare fittings are supplied with each switch. In most instances these fittings will prove sufficient to allow installation of the switch without the need for any special components. Pipe work can be used to support the switch, or the switch can be connected directly onto the discharge valve of a metering pump. The MF20 is terminated with 3/4" BSPP male threads. These can be screwed directly into pipe sockets, and used in 3/4" piping. In addition the switch is supplied with 3/4" unions and 1/2" (15NB) spigots. The spigots are thick walled and designed to be tapped 1/4BSP, for use with compression fittings, if required. The pipe spigots supplied with this switch constructed from PVC. Both types are suitable for solvent gluing directly into 15N/B PVC or ABS pipe fittings. In addition to the pipe spigots, each MF20 flow switch is supplied with 3 sets of tube flare fittings, these suit 6 by 4, 8 by 4 and 12 by 9 flexible tube.

FLOW SENSITIVITY & RESPONSE TIME

Sensitivity to fluid flow is a function of liquid viscosity and piston clearance. There are 3 pistons available to suit the MF20 flow switch. Each piston has a distinct switching point. The pistons are designated and marked A, B and C. The MF20 micro flow switch is supplied as standard with the "A" piston. The optional "B" and "C" pistons are also supplied with each switch. The following table sets out the performance parameters of the 3 pistons. The data is based on testing with water at 15°C as the test medium, and is accurate to +/-15%. Changes in liquid viscosity will affect the switching point. Increases in viscosity will proportionally decrease the flow rate required to actuate the switch, and will proportionally increase the response time. Decreasing viscosity will proportionally increase the flow required to actuate the switch, and will proportionally decrease the response time. Pistons are changed by unscrewing the inlet adaptor (part No 2), and inserting the new piston.

Note: The spanner octagon on the inlet adaptor accepts a standard gas cylinder spanner (28mm across the flats). Note: In pulsed flow applications where no pulse dampener is installed, and the pulse frequency is less than the electrical response time, the MF20 flow switch may respond with a train of on/off pulses rather than with a continuous on signal.

Data in the table below refers to the MF20-B and MF20-R models only. When using the MF20-C, for any given piston, multiply the switching flow rates in the table by 2.0 to obtain the correct values.

Piston Markings and Designation	Switching Point on a Rising Flow In Litres Per Hour	Switching Point on a Reducing Flow in Litres Per Hour	Electrical Response Time in Seconds on Cessation of Flow
A	0.32 +/- 15%	0.30 +/- 15%	4
B	3.10 +/- 15%	3.05 +/- 15%	3
C	12.8 +/- 15%	12.6 +/- 15%	2

Please Note: The type "A" piston is supplied as standard fitted to each switch, unless otherwise specified. The B & C pistons are included packed in with the switch.

MAINTENANCE

This flow switch is a very low maintenance device. Given the switch is appropriate and installed correctly, then a very long service life can be expected.



WARNING



All electrical work associated with the MF20 Series flow switch must be carried out by qualified electrical personnel and all electrical work must conform to AS/ NZ (or equivalent) standards and to local wiring rules.

ELECTRICAL INSTALLATION

The electrical enclosure on the MF20 switch is accessible by removing one screw on the lid. The lid has an integral 20mm cable gland designed to accept flexible cable up to 10mm diameter, or the gland nut can be removed and the exposed female thread will then accept a 20mm conduit bush. Various electrical options are available for the MF20 flow switch. Details of the specific circuit board module, including its model number are located inside the lid of the electrical housing of each switch. All the available electrical modules use a reed switch as the primary switching element. The contacts of the reed switch open and close in response to the position of the switch piston magnet. The reed switch may be the primary switch, or it may be used to drive a triac or a relay that is included on the circuit board in the switch. Where the reed switch is used as the main switch, care should be taken to ensure it is not overloaded. Reed switches are very reliable devices but may be damaged easily if overloaded. Use interposing relays and avoid inductive loads, fit suitable protection such as diodes or rate effect suppression circuits. Avoid capacitive coupling effects associated with long cable runs, use shielded cable in such situations, and fit diode protection to the reed switches in DC applications.

The MF20 switch can be tested for electrical function in the following way. With the switch isolated and held vertically, place a continuity tester across terminals S1 and S2. (Do not use a lamp tester for this, due to the high inrush current.) Use a pencil or similar object to lift the piston within the switch. Each time the piston is lifted a closed circuit should appear across S1 and S2. The piston is accessed by pushing the pencil straight up the centre of the switch, through the centre of the inlet fitting. This test should be done dry, and without the switch in the pipe work. Each time the piston is released it should fall freely to the off position, and the switch should respond with an open circuit across terminals S1 and S2.

SWITCH MODEL	MODULE TYPE	CONTACT CONFIGURATION	SWITCHED POWER MAXIMUM	SWITCHED VOLTAGE MAXIMUM	SWITCHED CURRENT RESISTIVE AC (RMS) MAXIMUM	INDUCTIVE LOADS (POWER FACTOR 0.4)	TYPICAL APPLICATION
MF20-B	Dry Reed Switch	S.P.S.T N.O	40 Watts	240V AC 200V DC	1 Amp	Not Suitable	PLC and General Control Circuits
MF20-C	Dry Reed Switch	S.P.D.T	20 Watts	140V AC 150V DC	1 Amp	Not Suitable	PLC and General Control Circuits
MF20-R	Solid State Relay (Triac)	S.P.S.T N.O	740 Watts	2 to 240V AC	4 Amp Continuous (Spike to 15A)	4A at 240V AC 5A at 30V DC	AC Control Circuits and AC Motor Control

NOTE: The MF20 micro flow switch uses reed switches as the primary switching element. Reed switches are one of the most reliable mechanical switching devices ever devised. They offer an operating life in excess of 100 million cycles, however, care needs to be taken to ensure they are not electrically overloaded or if applied in questionable applications, suitable protection should be added to the control circuit.

SPARE PARTS

All of the components of this switch are available as spare parts, as listed below

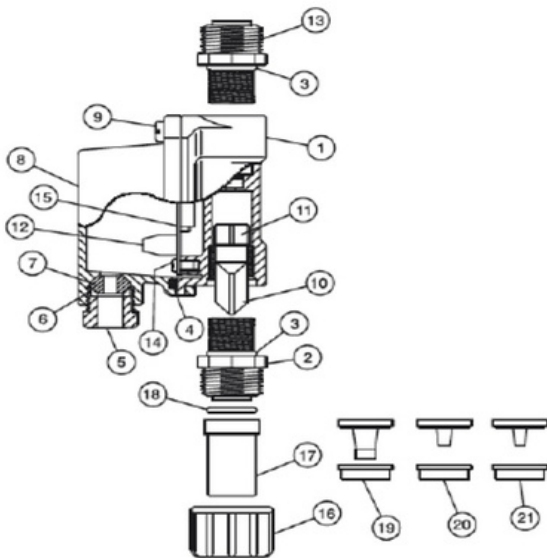

ITEM	DESCRIPTION	QTY	MATERIAL
1	SWITCH BODY	1	GLASS REINFORCED POLYPROPYLENE
2	INLET ADAPTOR	1	GLASS REINFORCED POLYPROPYLENE
3	O RING SEAL	2	EPDM ELASTOMER
4	MAIN LID GASKET	1	SANOPRENE
5	CABLE GLAND NUT	1	GLASS REINFORCED POLYPROPYLENE
6	CABLE GLAND THRUST RING	1	GLASS REINFORCED POLYPROPYLENE
7	CABLE GROMMET	1	SANOPRENE
8	LID	1	GLASS REINFORCED POLYPROPYLENE
9	LID FIXING SCREW	1	M5 BY 16 STAINLESS STEEL
10	PISTON	1	GLASS REINFORCED POLYPROPYLENE
11	MAGNET CASE	1	GLASS REINFORCED POLYPROPYLENE
12	TERMINAL BLOCK	1	ACETAL RESIN
13	OUTLET ADAPTOR	1	GLASS REINFORCED POLYPROPYLENE
14	CIRCUIT BOARD FIXING SCREW	2	M4 BY 6 STAINLESS STEEL PAN HEAD
15	CIRCUIT BOARD ASSEMBLY	1	COMPLETE ELECTRICAL MODULE
16	UNION NUT	2	GLASS REINFORCED POLYPROPYLENE
17	20/B PIPE TAIL	2	PVC
18	O RING SEAL	2	EPDM ELASTOMER
19	12 BY 9 TUBE ADAPTORS	2	ABS
20	8 BY 4 TUBE ADAPTORS	2	ABS
21	6 BY 4 TUBE ADAPTORS	2	ABS

Kelco Engineering Pty Ltd

ABN 20 002 834 844

Head Office & Factory
9/9 Powells Road,
Brookvale 2100 NSW Australia

Postal Address
PO Box 7485 Warringah Mall
Brookvale 2100 NSW Australia

Phone: +61 2 99056425
Fax: +61 2 9905 6420

Email: Sales@kelco.com.au
Web: www.Kelco.com.au

PLEASE NOTE: Kelco Engineering Pty Ltd reserves the right to change the specification of this product without notice. Users will use their own judgment to determine the appropriateness of using Kelco Products in an application, any safety measures required and that the product is properly installed for that application. To the extent permitted by law Kelco Engineering Pty Ltd disclaims and excludes all and any liability for the use of this product in any particular application or for defective installation. Kelco switches are warranted against malfunction by a 12 month return to base manufacturer's warranty. Full details of our warranty and limitation of liability can be found in this document or downloaded from: <http://www.kelco.com.au/warranty>

Warranty and Limitation of Liability

Thank you for purchasing Kelco Engineering Pty Ltd, (ABN 200 002 834 844) ("Kelco") products (*Kelco Products*). This document sets out the terms and conditions of the product warranty and Limitation of Liability for *Kelco Products*. It is an important document. Please keep it with your proof of purchase documents in a safe place for future reference should you need to lodge a claim.

This Warranty and Limitation of Liability (or any more recent version in effect when you purchase a *Kelco Product*) ("*Warranty*") applies to all *Kelco Products* regardless of where you purchased the *Kelco Products*.

When you place an order, you are deemed to agree to the *Warranty*, unless otherwise agreed in writing with Kelco.

Kelco is located at 9/9 Powells Road, Brookvale, NSW 2100, AUSTRALIA and may be contacted by calling 61 2 99056425 or emailing: sales@kelco.com.au

1. Definition

The following terms used herein are defined as follows:

- (1) *Australian Consumer Law or ACL*: Schedule 2 to the Competition and Consumer Act 2010 (Cth).
- (2) *Brochures and Technical data sheets*: Kelco brochures, including, without limitation, sales brochures and technical data sheets, whether or not provided electronically.
- (3) *Customer Application*: Any application of *Kelco Products* or component parts by a you including, but not limited to, embedding and/or using *Kelco Products* in your parts/components, electronic substrates, devices, equipment and /or systems manufactured by customers.
- (4) *Non- Excludable Guarantee*: a Consumer Guarantee applicable to these *Warranty Terms* under the *Australian Consumer Law or New Zealand Consumer Guarantee Act 1993*.
- (5) *Fitness*: (a) fitness for a particular purpose, (b) performance, (c) compliance with laws and regulations and (d) conformity to standards of a *Kelco Product*.
- (6) *Kelco Products*: flow switches, level switches and float switches, related products and electronic/mechanical components under the *Kelco* brand.
- (7) 'You' or "Customer" means the purchaser of the *Kelco Products* not having purchased the *Kelco Products* for re-sale, and 'your' has a corresponding meaning.
- (8) *Usage Conditions*: Usage conditions, rating, performance, operating environment, handling instructions, warnings, restrictions on use, etc. of *Kelco Products* described in the *Brochures and technical data sheets*.

2. Descriptions

You are deemed to accept the following terms and conditions regarding the descriptions provided of *Kelco Products* in the *Brochures and technical data sheets* when you adopt or use a *Kelco Product* or component thereof.

- (1) Rated values and performance values are based on average performance established from batch production runs and Kelco does NOT warrant any rated values and performance values for multiple composite conditions.
- (2) Reference data is provided for your reference only. Kelco does NOT warrant that *Kelco Products* work properly at all times or continuously as provided in the reference data.
- (3) Application examples (if any) are provided for your reference only. Kelco does NOT warrant the *Fitness of Kelco Products* under such applications.
- (4) Kelco may discontinue the production of *Kelco Products* or change their specifications for the purpose of improving such products or for other reasons entirely at its own discretion and is under no obligation to notify you of any such change.

3. Precautions

You are deemed to accept the following terms and conditions when you purchase *Kelco Products*:

- (1) You will use *Kelco Products* in compliance with *Usage Conditions* including rating and performance.
- (2) You will confirm *Fitness* and use your own judgment to determine the appropriateness of using of *Kelco Products* in a *Customer Application*. *Kelco products* are unlike conventional flow and level switches and pump controllers in that they can be applied to virtually any fluid or pumping system in any manner defined by an original equipment manufacturer, a wholesaler or end user or their agents. The knowledge and experience of such parties is outside the control of Kelco, and their having relevant knowledge and experience is critical to the successful application and operation of the *Kelco Products*. Kelco does NOT warrant the *Fitness of Kelco Products* in a *Customer Application*.
- (3) You will confirm that *Kelco Products* are properly wired and installed for their intended use in your overall system. In the case of *Kelco* pump controllers, the flexibility of their operating system means it requires an extensive knowledge of pumps and their characteristics and the intended overall goal of the system in order to select the correct functions and settings. Failure to understand the ramifications of incorrect settings may result in a system that fails to perform to your expectations and or may even damage the pump or system itself. It is therefore critical that correct settings are used to achieve a stable and reliable overall system and to provide any such system with appropriate pressure and or flow protection the pump controller is intended to provide. Kelco does NOT warrant *Kelco Products* against defective installation, incorrect programming, incorrect wiring or electrical overload in any form.
- (4) When using *Kelco Products*, you will make sure to (i) maintain a margin of safety in relation to the published rated and performance values, (ii) design to minimize risks to any *Customer Application* in case of failure of any *Kelco Products*, such as introducing redundancy i.e. critical systems should include double redundancy of all controls, (iii) adopt system-wide safety measures to notify risks to users such as independent backup protection. Such backup may consist of a simple or complex independent alarm system to alert an operator to any issue with the system, and (iv) conduct regular maintenance on *Kelco Products* and the *Customer Application*.
- (5) It will be your sole responsibility as user to determine and use adequate measures and checkpoints to satisfy your particular requirements for (i) data input and output, (ii) maintaining a means for reconstruction of lost data, (iv) preventing *Kelco Products* installed thereon from being infected with computer viruses and (v) protecting *Kelco Products* from unauthorized access. Kelco shall not be responsible and/or liable for any loss, damage, or expenses directly or indirectly resulting from any third-party software or hardware not contained in the product as originally configured by the manufacturer, the infection of *Kelco products*, or any computer equipment, computer programs, networks, databases or other proprietary material connected thereto, by service attack, computer viruses, other technologically harmful material and/or unauthorized access.
- (6) *Kelco Products* are designed and manufactured as general-purpose products for use in general industrial products. They are not intended to be used in the applications described in subsection 3...(5)(a), (b), and (c). If you are using *Kelco Products* in the applications described below, Kelco does not provide any warranty for such *Kelco Products*, except for specific applications where Kelco has specified that it intends to provide a warranty or by separate written agreement between the customer and Kelco.

- a. Applications with stringent safety requirements and applications that could cause physical injury to a person or result in loss of life.
- b. Applications under severe conditions or in severe environment, including but not limited to outdoor equipment, equipment exposed to chemical contamination, equipment exposed to electromagnetic interference and equipment exposed to vibration and shocks.

- c. Applications under conditions or environments not described in any of the Brochures and Technical data sheets.
- d. *Kelco Products* are not intended for use in Hydrocarbons other than Dieseline.

4. Warranty

Kelco warrants that *Kelco Products* will perform in accordance with the specifications set out in the Technical data sheets, subject to and in accordance with the following:

- (1) Warranty period: The *Warranty* shall apply for 12 months from the date of original purchase of *Kelco Products* by the customer. .
- (2) Sole Remedy: Unless required to do otherwise as a result of statutory guarantees applicable under *ACL*, *Kelco* will provide, at its own discretion, either of the following two services as the sole remedy for a malfunctioning *Kelco Product*:
Repair of the malfunctioning *Kelco Product(s)* or components by *Kelco* or *Kelco* authorised dealer at no charge to the customer, or

- a. Replacement of the malfunctioning *Kelco Product(s)* or components by *Kelco* or *Kelco* authorised dealer with the same number of replacement/alternative products or components at no charge to the customer.

(3) Exceptions: This *Warranty* of *Kelco Products* does not apply if the cause of the malfunction falls under any of the following:

Usage in a manner other than the original intended use for the *Kelco Products* or component thereof.

- a. Usage other than as described in the *Usage Conditions*.
- b. Usage that is not in accordance with Section 2 (Descriptions) and Section 3 (Precautions) above.
- c. Modification or repair made to the *Kelco Products* by persons other than *Kelco*.
- d. Causes which could not have been foreseen with the level of science and technology at the time of shipping from *Kelco*.
- e. Replacement or repair of any (1) consumables (including cables, paddles and circuit boards), or (2) lost parts or accessories.
- f. Service of any product whilst it is outside Australia.
- g. Causes originating from other than *Kelco* or *Kelco Products* (including force majeure such as but not limited to natural disasters)
- h. Causes from any environmental factors. Such factors may include but are not limited to water or chemical ingress, fire damage, lightning damage, mechanical damage, sun damage or degradation, failure due to over-heating, freezing or vibration. Failure due to customers over tightening threads or fittings. Failure due to power supply fluctuations, surges, spikes, brown outs. or AC supplies that do not provide a pure sine wave output.
- i.

(4) If you intend to make a claim under this *Warranty* you must contact *Kelco* to register your claim by telephone on (02)99056425 and provide the following details to enable *Kelco* to assess the claim: (i) proof of purchase; (ii) evidence of the particulars of the claim that gives rise to the application of the *Warranty* ; (iii) confirmation that the cause of the malfunction was not an Exception set out above; and (iv) your phone number, email and address details.

You must provide or make the *Kelco product* available to *Kelco* for evaluation. If you are required to return the product to *Kelco* for repair replacement or evaluation, *Kelco* will provide delivery details and a return goods authorisation number to you. The *Kelco Products* will be at the owner's risk whilst in transit to and from *Kelco*, unless transported by *Kelco* or its authorised representatives.

The *Kelco Product* presented for repair may be replaced by refurbished products of the same type rather than being repaired. Refurbished parts may be used to repair the product.

To the extent permitted by law replacement of the product or a part does not extend or restart the *Warranty Term*.

Kelco may seek reimbursement of any costs incurred by them when the *Kelco* product is found to be in good working order.

5. Non-excludable Statutory Guarantees

(1) The *Warranty* is given by *Kelco* in addition to other rights and remedies which you may be entitled to under by law, nothing contained in this agreement excludes, restricts or modifies any condition, guarantee, warranty or other obligation which is applicable to or is conferred on *Kelco* pursuant to law where to exclude, restrict or modify any such condition, warranty or other obligation is unlawful. (2) Australia: To the extent that you are a consumer for the purposes of the *ACL*, *Kelco Products* come with guarantees that cannot be excluded under the *ACL*. You are entitled to a replacement or refund for a major failure and compensation for any other reasonably foreseeable loss or damage. You are also entitled to have the goods repaired or replaced if the goods fail to be of acceptable quality and the failure does not amount to a major failure. "Acceptable Quality" and "major failure" have the meaning they have in the *ACL*. (3) New Zealand: For *Kelco Products* provided by *Kelco* in New Zealand, the *Kelco Products* come with a guarantee by *Kelco* pursuant to the provisions of the Consumer Guarantees Act, section 345(1)(i) of the Contract and Commercial Law Act 2017 and the Fair Trading Act. Where the *Kelco Product* was purchased in New Zealand for commercial purposes the Consumer Guarantee Act does not apply.

6. Disclaimer and Limitation of Liability

TO THE EXTENT PERMITTED BY APPLICABLE LAW:

(1) SELLER MAKES NO WARRANTY, EXPRESS OR IMPLIED, OTHER THAN AS STATED IN SECTION 4 ABOVE AND SELLER DISCLAIMS AND EXCLUDES ANY WARRANTY OF ANY OTHER KIND. (2) THE SOLE AND EXCLUSIVE REMEDY FOR MALFUNCTIONING KELCO PRODUCTS SHALL BE AS SET FORTH IN SECTION 4. ABOVE. (3) *KELCO* AND THE DISTRIBUTORS OF *KELCO PRODUCTS* ARE NOT LIABLE FOR ANY DAMAGES WHICH MAY ARISE FROM OR BE RELATED TO *KELCO PRODUCTS*.

7. Confidentiality: You accept that if you make a *Warranty* claim, *Kelco* and its agents may exchange information in relation to you to enable *Kelco* to meet its obligations under this *Warranty*.

8. Export/ Import Controls

Customers of *Kelco Products* shall comply with all applicable laws and regulations of Australia and/or other relevant countries with regard to security export/import control, when exporting/importing *Kelco Products* and/or technical documents or providing such products and/or documents to a non-resident of Australia. At its discretion *Kelco* may not provide customers with *Kelco Products* and/or technical documents should they fail to comply with such laws and regulations.

Kelco Engineering Pty Ltd

ABN 20 002 834 844

Head Office & Factory
9/9 Powells Road,
Brookvale 2100 NSW Australia

Postal Address
PO Box 7485 Warringah Mall
Brookvale 2100 NSW Australia

Phone: +61 2 99056425
Fax: +61 2 9905 6420

Email: Sales@kelco.com.au
Web: www.Kelco.com.au

PLEASE NOTE: Kelco Engineering Pty Ltd reserves the right to change the specification of this product without notice. Users will use their own judgment to determine the appropriateness of using Kelco Products in an application, any safety measures required and that the product is properly installed for that application. To the extent permitted by law Kelco Engineering Pty Ltd disclaims and excludes all and any liability for the use of this product in any particular application or for defective installation. Kelco switches are warranted against malfunction by a 12 month return to base manufacturer's warranty. Full details of our warranty and limitation of liability can be found in this document or downloaded from: <http://www.kelco.com.au/warranty>